

# **GLOBAL**

---

**WF995AUT**

**Top and Bottom Feed Lockstitch  
(With Automatic Trimmer)  
Sewing Machine**

**INSTRUCTION MANUAL  
CATALOG**

---

## **1、 Safety precautions:**

- 1) When turning the power on, keep your hands and fingers away from the area around/under the needle and the area around the pulley.
- 2) Power must be turned off when the machine is not in use, or when the operator leaves the seat.
- 3) Power must be turned off when tilting the machine head, installing or removing the “V” belt, adjusting the machine, or when replacing.
- 4) Avoid placing fingers, hairs, bars etc., near the pulley, “V” belt, bobbin winder pulley, or motor when the machine is in operation.
- 5) Do not insert fingers into the thread take-up cover, under/around the needle, or pulley when the machine is in operation.
- 6) If a belt cover, finger guard, eye guard are installed, do not operate the machine without these safety devices.

## **2、 Precautions before starting operation:**

- 1) Never operate the machine before filling the machine’s oil pan.
- 2) When a new sewing machine is first turned on, verify the rotational direction of the pulley with the power on.
- 3) Verify the voltage and phase (single or three) with those given on the machine nameplate.

## **3、 Precautions for operating conditions:**

- 1) Avoid using the machine at abnormally high temperatures (35°C or higher) or low temperatures (5°C or lower) .
- 2) Avoid using the machine in dusty conditions.

#### 4. Specifications:

Model		WF 995AUT
Specifications		
Material weight		Heavy
Max. sewing speed		2,000 rpm
Stitch length		0—8.0 mm
Needle bar stroke		38.0 mm
Thread take-up lever stroke		73.0 mm
Alternating movement		2.0-5.0 mm
Walking foot alternate operating system		Dial
Feed dog height		1.0 mm
Needle		DP×17 22#
Presser foot stroke	By hand	6.0 mm
	By knee	16.0 mm
Hook		Fully rotating automatic lubrication (for thread trimmer), Large
Lubrication system		Automatic
Thread trimmer		○
Touch back		○

#### 5. Installing the belt (Fig.4):

- 1) Use a V-belt for sewing machine use, type M.
- 2) To adjust the belt tension, change the motor height by turning the tension adjust nuts so that the belt sinks about 15mm when depressed by hand at the center of the belt span.

If the tension is too low, the speed may not be consistent in the low or

## 6. Adjustment of needle bar stop position(Fig5, Fig6, Fig7):

### 1) Adjustment of "UP" position

When the pedal is kicked down by heel to cut the thread, the machine stops in the "UP" position. If the marks deviate more than 3mm, adjust as follows:

- (1) Disconnect the plug (12 pins) from the control panel;
- (2) Run the machine and stop in the "UP" position;
- (3) While holding the pulley, insert the adjusting tool into the two holes marked "A", then rotate the pulley.

### 2) Adjustment of "DOWN" position

When the pedal is returned to the neutral position, the machine stops in the "DOWN" position. If the marks deviate more than 3mm, adjust as follows:

- (1) Disconnect the plug (12 pins) from the control panel;
- (2) Run the machine and stop in the "DOWN" position;
- (3) While holding the pulley, insert the adjusting tool into the two holes marked "B", then rotate the pulley.

3) Confirm the stop operation then the plug (12 pins) coming from the machine head into the receptacle.

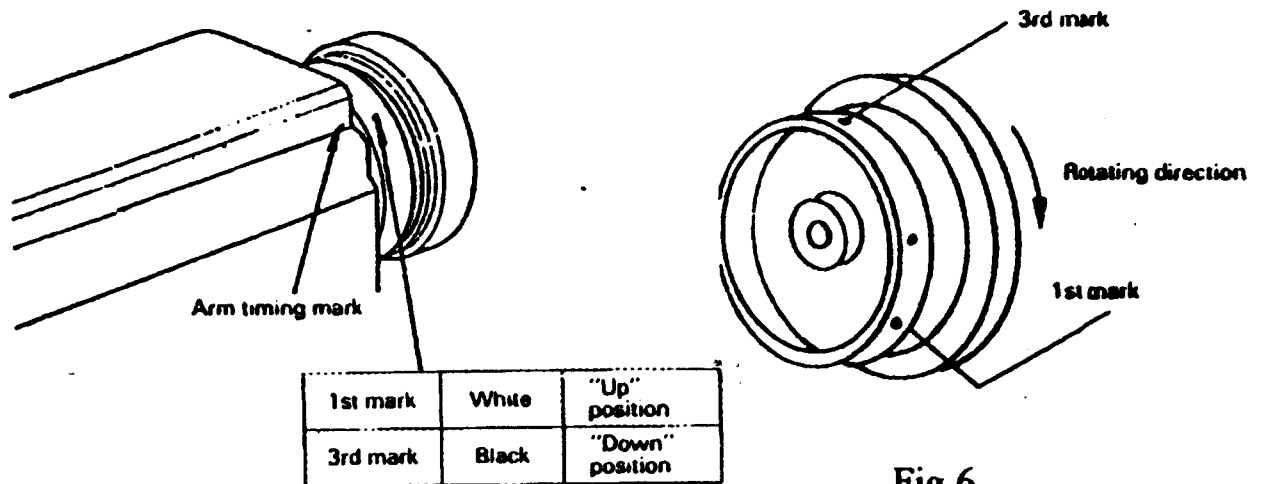

Fig.5

Fig.6

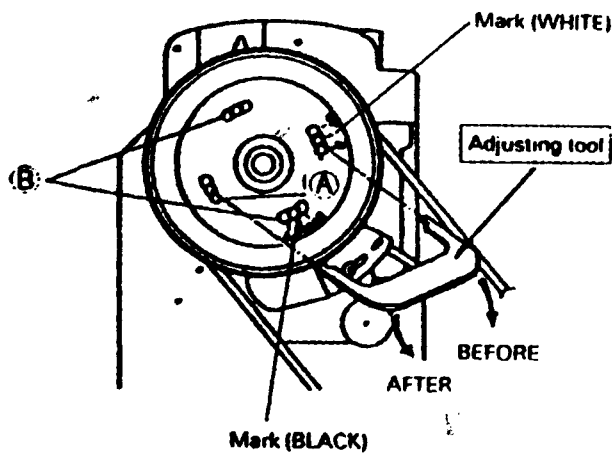

Fig.7

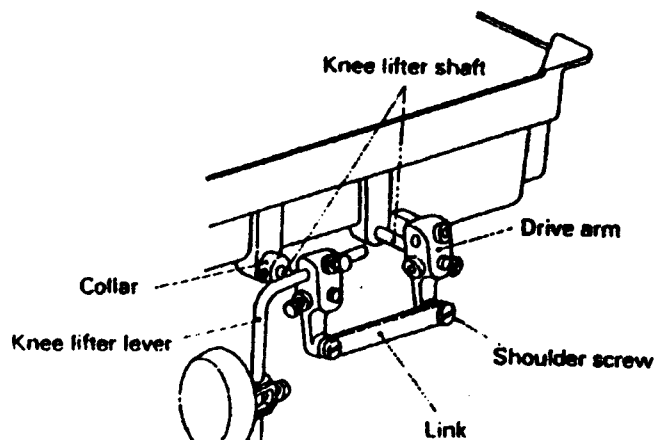

Fig.8

## 9、 Installing the knee lifter (Fig.8) :

- 1) Pull out the knee lifter shafts (on the right and left) as far as possible, and properly set them.
- 2) Install the drive arm on each shaft.
- 3) Set a link between the right and left drive arms to connect them.
- 4) Install the knee lifter lever on the left drive arm.

## 10、 Lubrication (Fig.9):

Pour oil up to position "A" of the oil tank.

During operation, check the oil level periodically, and in cases where the oil level is below position "B", replenish the oil supply up to position "A".

Use white spindle oil.

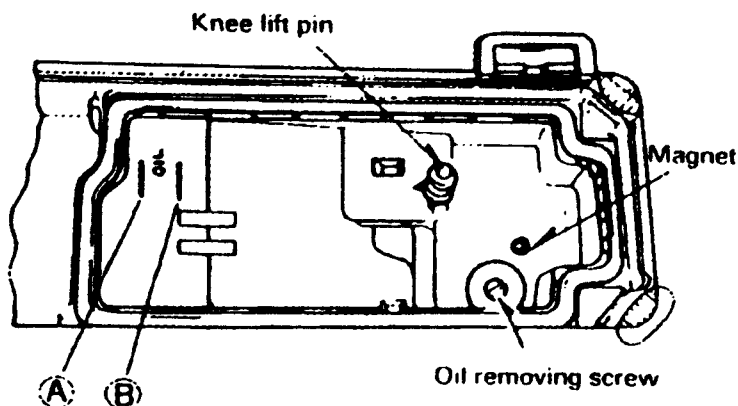

Fig.9

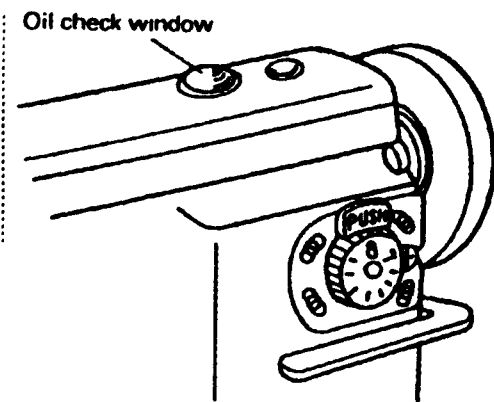

Fig.10

## 11、 Condition of oil lubrication (Fig.10):

While operating the machine, check the condition of oil lubrication through the oil check window.

## 12、 Adjustment of the hook lubrication (Fig.11):

Adjustment can be done by turning screw "A".

(1) When the screw has been fully tightened ..... Maximum

(2) When the screw has been fully loosened ..... Maximum

**Note:** After adjustment of this screw, the machine should be operated for at least 30 seconds, then check the oil mist from the hook.

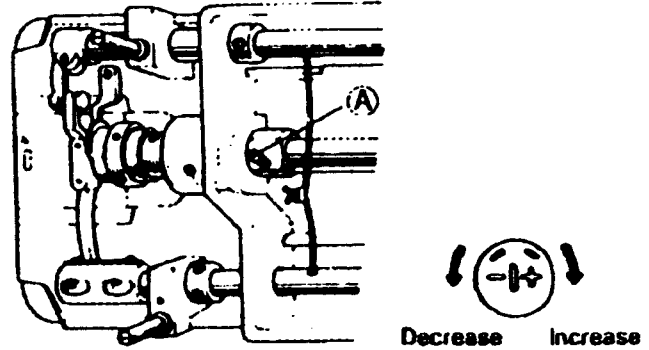

Fig. 11

## 13、 Adjustment of oil pump (图 12):

The standard adjustment is as follows:

The adjusting plate keeps the bypass hole fully closed. To decrease splashing, open the bypass hole appropriately.

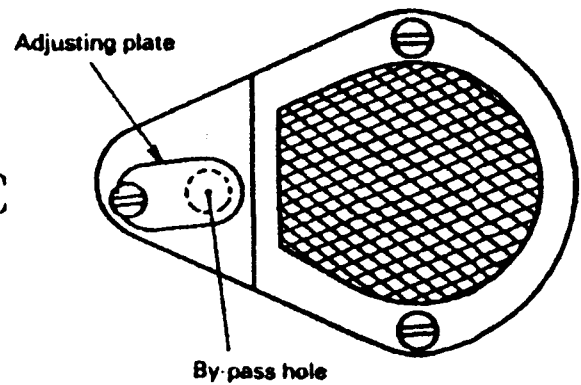

Fig. 12

## 14、 Periodical cleaning (Fig.13, Fig.14, Fig.15):

Clean the feed dog, hook and oil pump periodically.

Maintenance of motor: Remove dust from the motor filter every one or two months.

Control box: Remove dust from the connector.

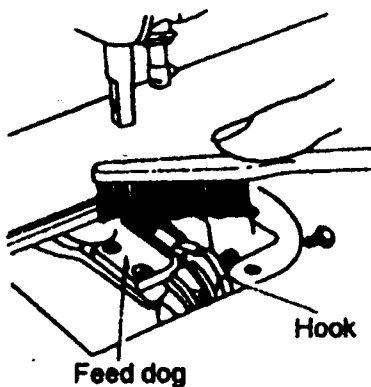

Fig. 13

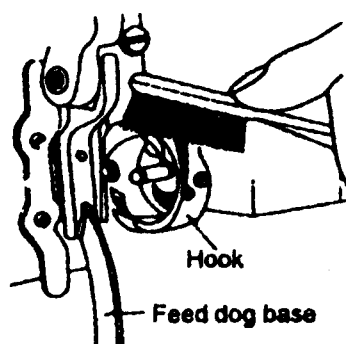

Fig. 14

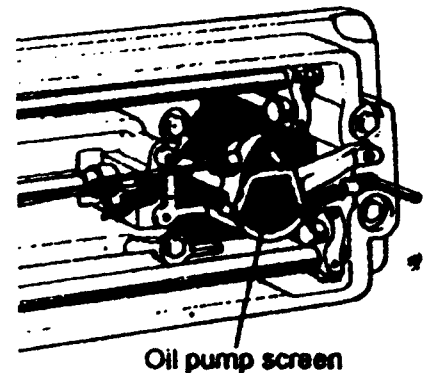

Fig. 15

## 16、 Installation of belt cover:

Be sure to install the belt cover for safety.

## 17、 How to wind the lower thread (Fig.17):

**Strength of winding:** Particularly in the case of nylon or polyester thread, wind the bobbin loosely.

**Uneven winding:** If the bobbin is wound unevenly, slide the thread guide toward the less wound portion of bobbin.

**Winding amount:** When the bobbin is wound excessively, loosen the adjusting screw. When the bobbin is wound insufficiently, tighten the adjusting screw.

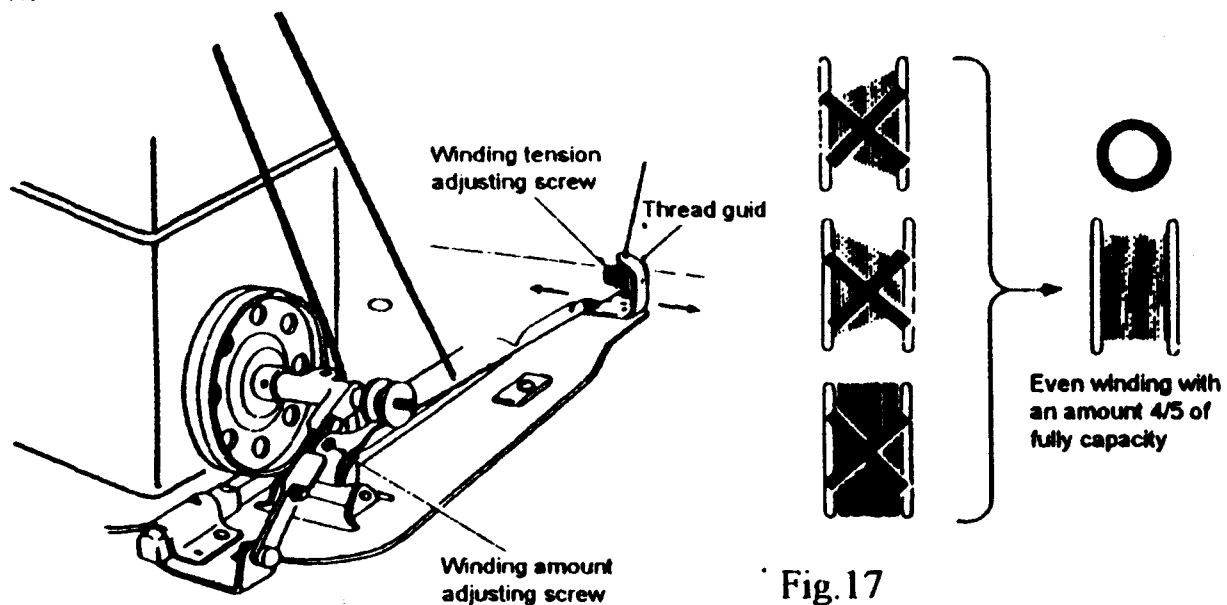

Fig.17

## 18、 How to attach a needle (Fig.18):

**Note:** Before attach the needle, be sure to turn the power switch off.

**Note:** If thread snapping occurs during reverse sewing with polyester, it may be avoided by fitting the needle with the long groove shifted to the front side. Normally, avoid fitting the needle with the groove facing backward.

Insert the needle until it bottoms, and tighten the screw keeping the long groove in the needle facing to the left.

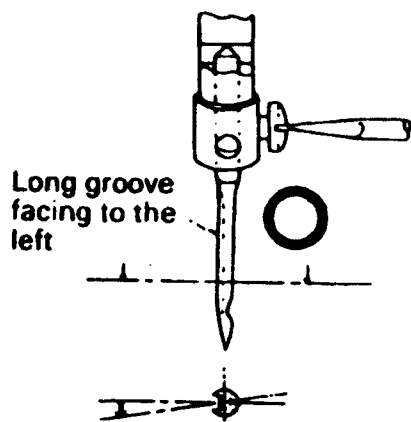

Insufficient insertion

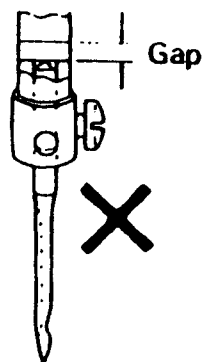

Wrong direction

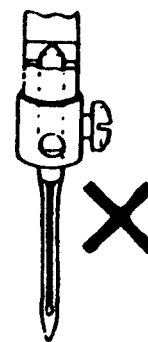

Fig.18

## 19、 How to route the upper thread (Fig.19):

Raise the thread take-up lever to its highest possible position, and route the upper thread in the order illustrated below.

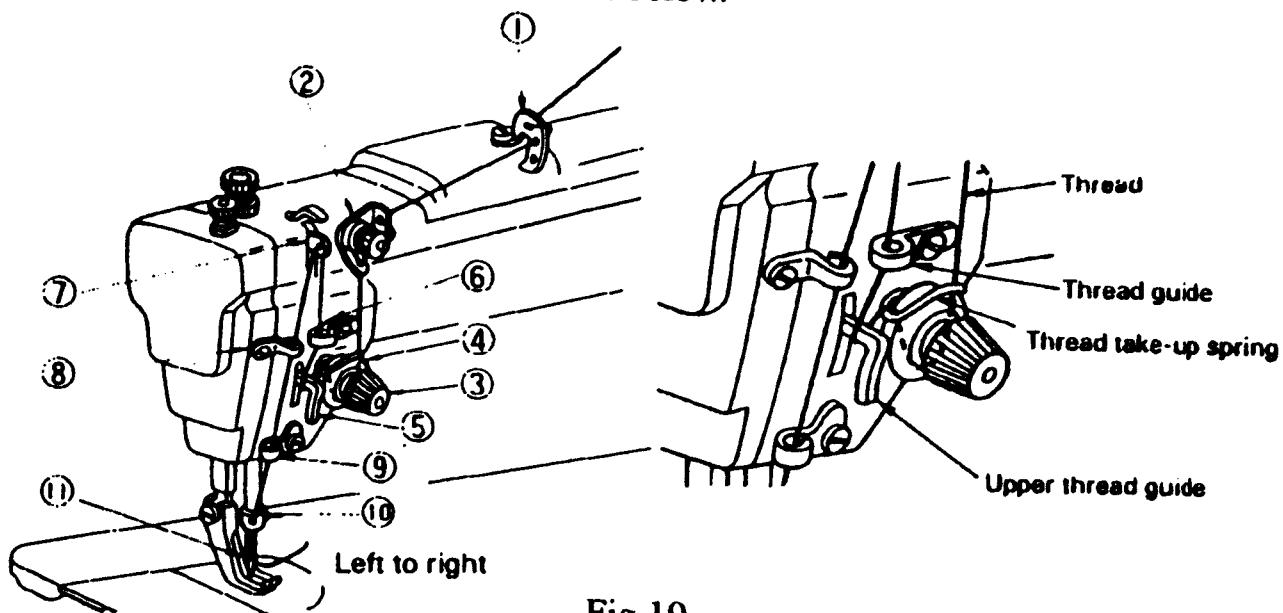
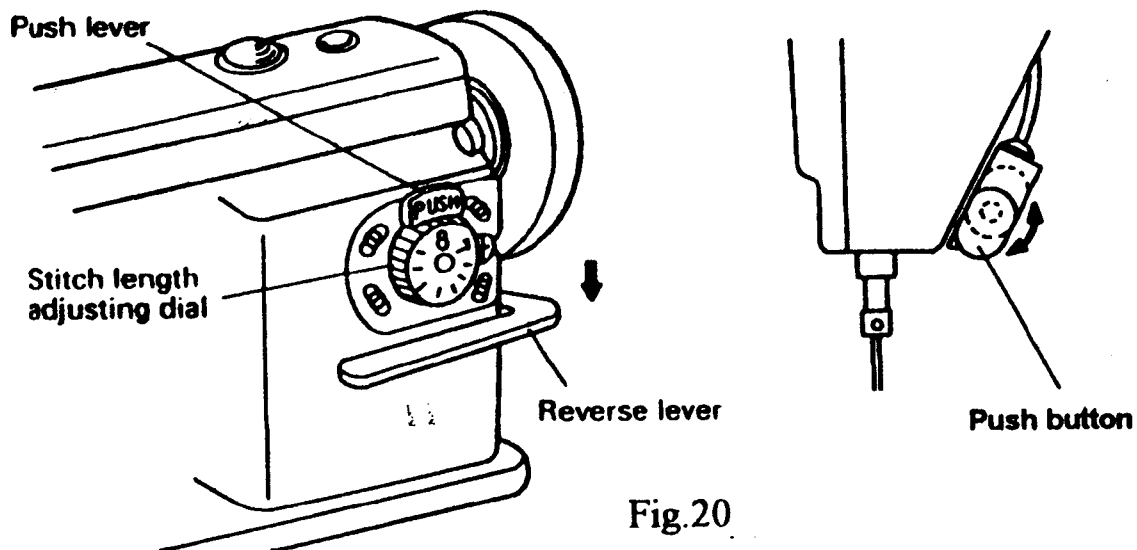

Fig.19

## 20、 Adjustment of stitch length and reverse sewing (Fig.20):

- 1) To change the stitch length, rotate the stitch length adjusting dial while pressing the "push" lever.
- 2) Pressing the stitch length adjusting lever for reverse stitching.





## 21. Adjusting the thread tension (Fig.21):

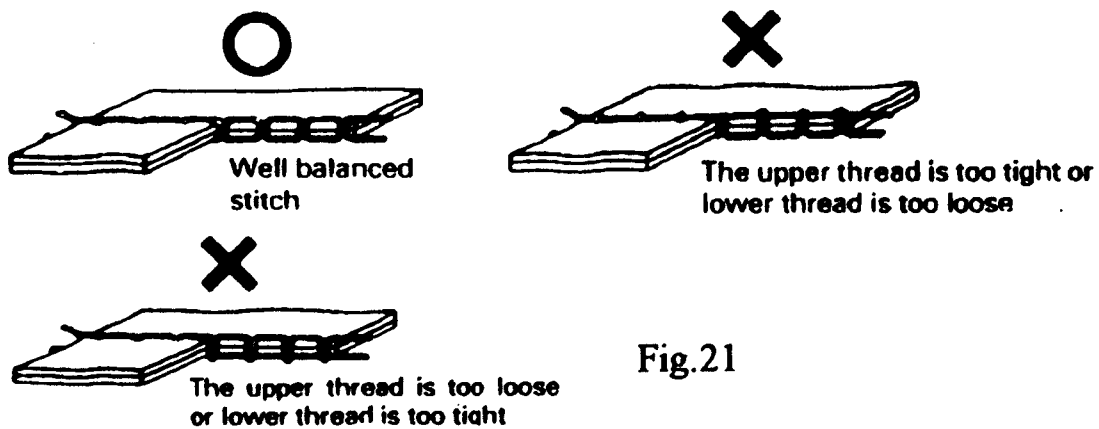

## 22. Upper thread tension (Fig.22):

- 1) The upper thread can be adjusted based on the lower thread tension.
- 2) Adjustment can be done by rotating the thread tension nut.

For special fabric sewing with special thread, the desired tension can be obtained by adjusting the strength and operating range of thread take-up spring.

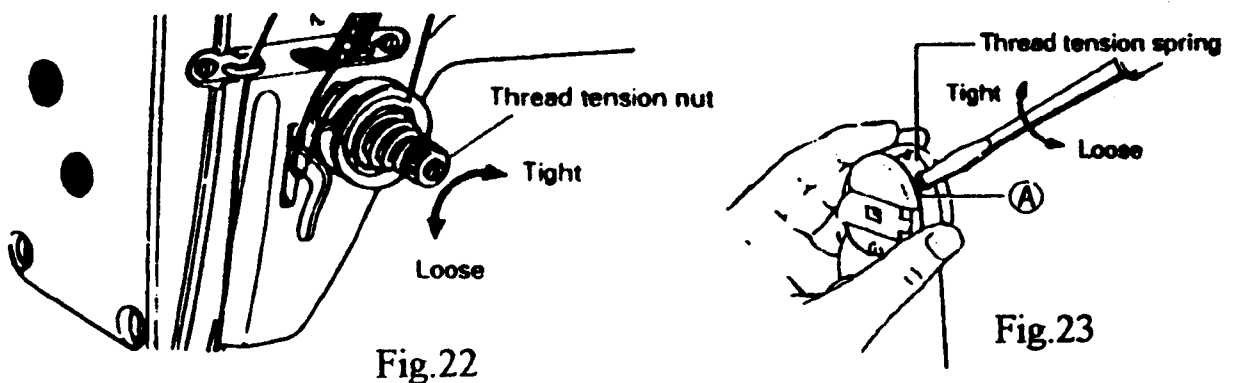

### 23、 Lower thread tension (Fig.23):

Lower thread tension can be adjusted by rotating screw "A".

### 24、 Adjustment of presser pressure (Fig.24):

- 1) Pressure should be adjusted according to the material to be sewn.
- 2) Pressure on both the walking foot and the presser foot can be adjusted.
- 3) Sewing pressure should be adjusted to the minimum required strength.

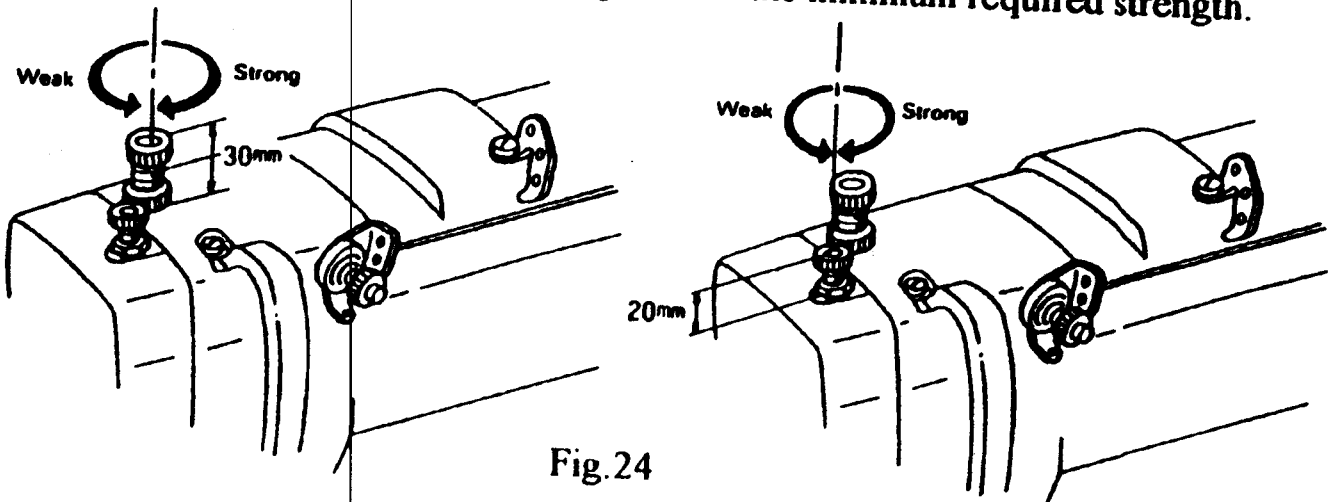



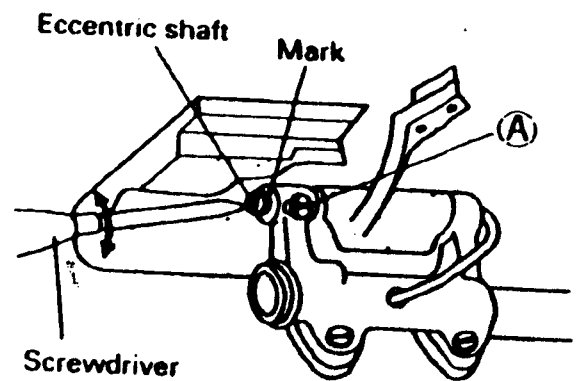
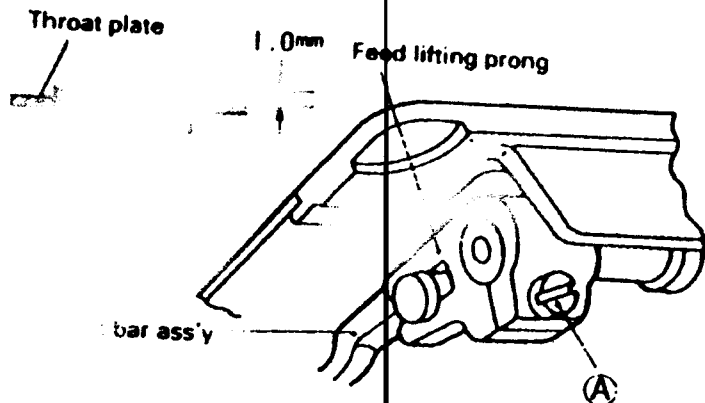

### 25、 Feed dog height (Fig.25):

- 1) Feed dog should be 1.0mm higher than the throat plate.
- 2) To adjust the dog height as follows:
  - (1) Loosen the screw "A", move the feed bar upward and downward.
  - (2) When adjustment is completed, tighten the screw "A"



## 26. Adjustment of feed dog inclination (Fig.26):

If necessary, adjust the inclination according to the material to be sewn as follows:

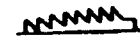
Position of mark on the eccentric shaft	Feed dog
 Horizontal	 Standard
 Up	 Front up (MAX.)
 Down	 Front down (MAX.)

- 1) Loosen the screw "A".
- 2) Rotate the eccentric shaft clockwise or counterclockwise with screw driver.
- 3) Tighten the screw "A".

## 27. Adjustment of stitch length and forward/backward sewing (Fig.27):

- 1) Loosen the set screws located in the bracket.
- 2) Rotate the stitch length adjusting pin until the desired length is reached as follows:
  - (1) Clockwise: Increases the stitch length in forward sewing, and decreases the stitch length in backward sewing.
  - (2) Counterclockwise: Decreases the stitch length in forward sewing, and increases the stitch length in backward sewing.

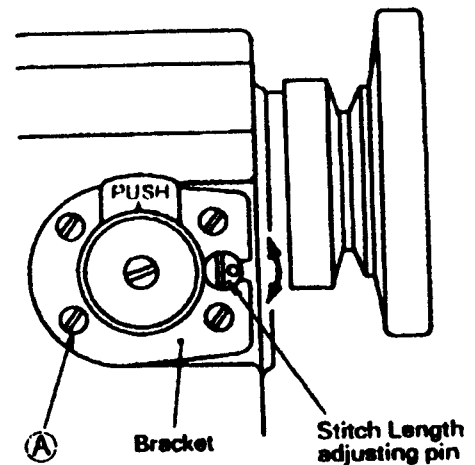

Fig.27

## 28. Presser bar lifter (Fig.28):

Rotate the presser bar lifter in the direction of the arrow. This raises the presser foot.

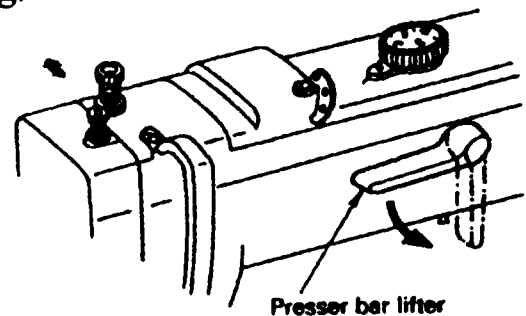

Fig.28

## 29、 Adjustment of walking foot and presser foot:

### 1) Adjustment of alternating movement (Fig.29):

(1) The alternating movement on the walking foot and presser foot can be adjusted by using adjusting dial located on the top cover.

(2) Face the desired number printed on the dial to the matching mark located on the top cover. The number printed on the dial represents the possible protrusion of the walking foot and presser foot from the throat plate when the alternating movements on these are evenly set.

(3) The alternating movements can be readjusted up to 2.0-5.0mm.

### 2) To change the balance of the alternating movements between the walking foot and presser foot (Fig.30):

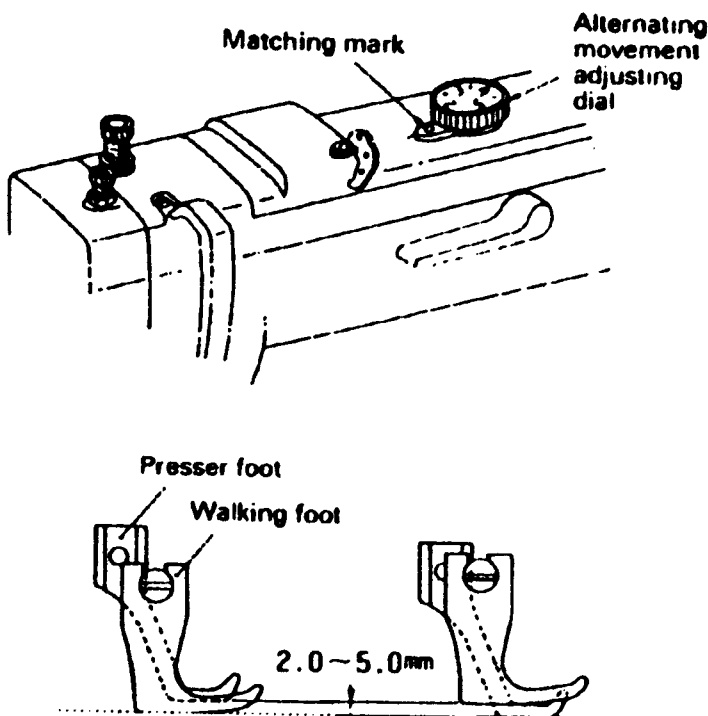

Fig.29

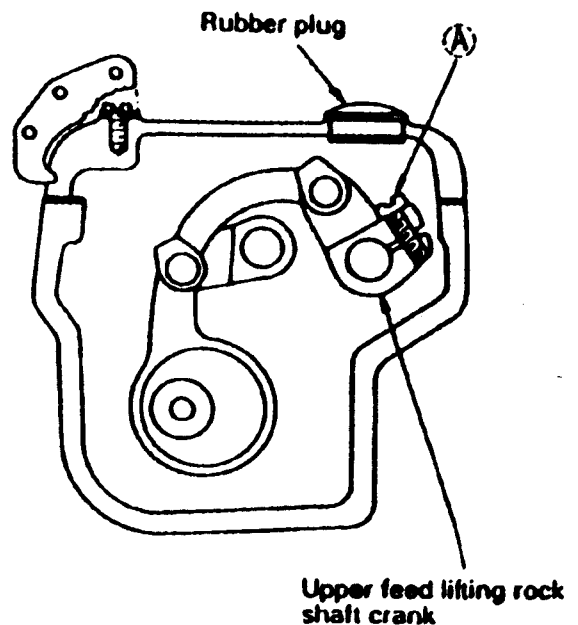

Fig.30

(1) To increase the rise of the walking foot and decrease the rise of the presser foot:

- ① Remove the rubber plug of top cover.
- ② Rotate the pulley until the presser foot is slightly raised from the throat plate.

- ③ Loosen screw "A" (on the right side)
- ④ The built-in spring pulls down the presser foot until it makes contact with the throat plate. Tighten the screw "A".
- ⑤ After this adjustment, the protrusion of the presser foot has been decreased by a set distance. And the vertical motion of the walking foot has been increased by the same distance.

(2) As a contrary case (1) , to decrease the rise of the walking foot and increase the rise of presser foot as follows:

Fist, rotate the pulley until the walking foot is slightly raised from the throat plate. Next, loosen screw "A". Finally, tighten screw "A". This decreases the rise of the walking foot.

3) Installing the feed regulator bracket (Fig.31):

**Note: If the feed regulator bracket is poorly positioned, the resultant alternating movements may be too short or long, causing defective machine operation.**

(1) Set the clearance between special screw "A" located on the regulator stud and the side wall of the machine arm to 26.5mm as Fig.31.

(2) With the feed regulator stud held as explained is step (1) above, adjust the feed regulator bracket. This adjustment should insure a clearance of 12mm between the periphery of pin "B" located on the feed regulator bracket and the top cover mounting face located on the arm. Tighten screw "C".

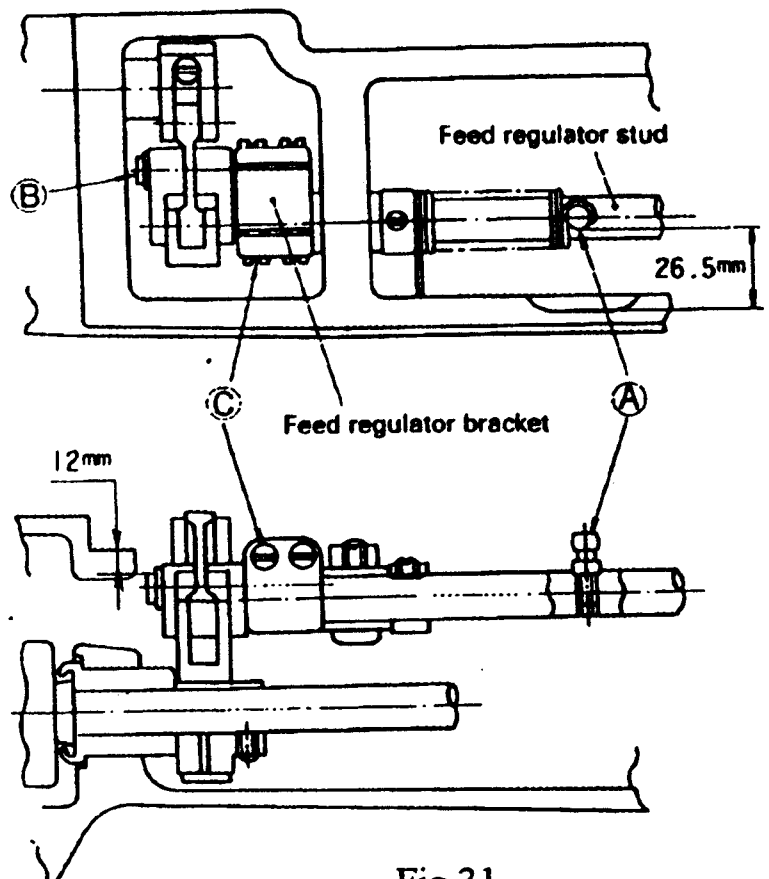

#### 4) Feed pitch adjustment of walking foot (Fig.32):

The ratio of the upper feed amount (of the walking foot) to the lower feed amount (of the feed dog) has been adjusted to 1:1. However, the walking foot feeding amount can be increased or decreased depending on the operating conditions.

Loosen the nut located on the upper feed rock shaft crank (left), and shift to adjust the position of the pivot bracket upward or downward.

Upper position → Feed pitch → Small

Lower position → Feed pitch → Large

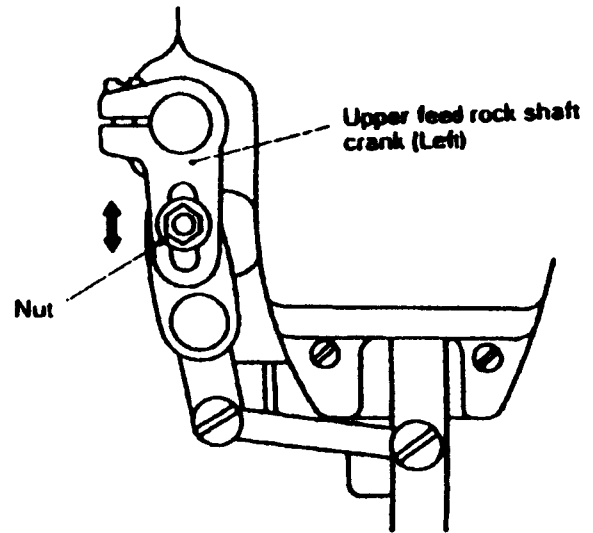

Fig.32

### 30、 Adjustment of feed timing (Fig.33):

1) The standard position of the eccentric feed cam and eccentric feed lifting cam are illustrated to Fig.33

2) Open the top cover, properly slide the eccentric ring to adjust the position.

3) The eccentric feed cam can also be adjusted by removing the rubber plug located on the top cover. In the latter case, however, the built-in bevel gear is concealed; care should be taken when adjusting.

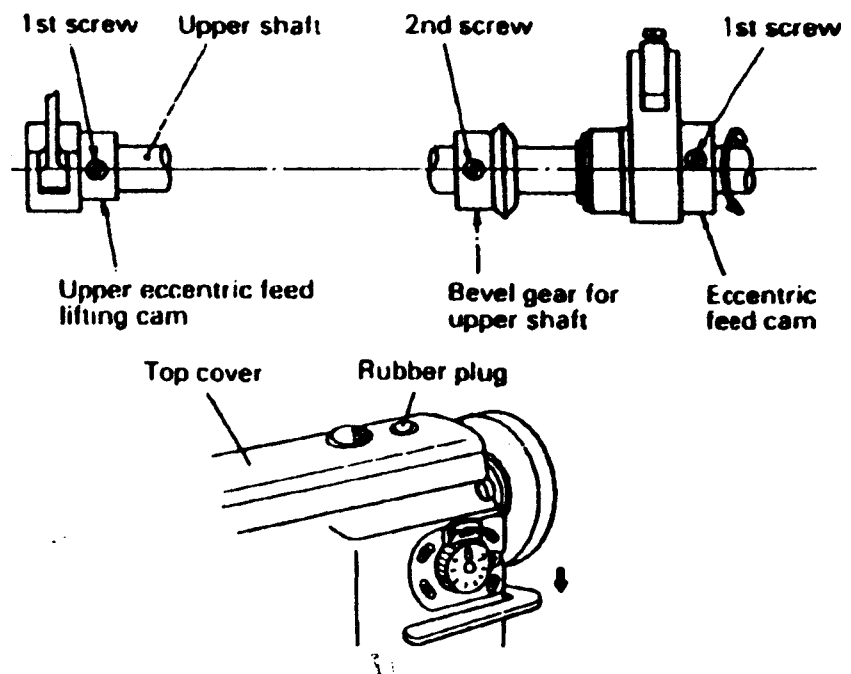

Fig.33

### 31. Adjustment of thread trimmer mechanism:

1) The thread trimmer mechanism illustrated as Fig.34.

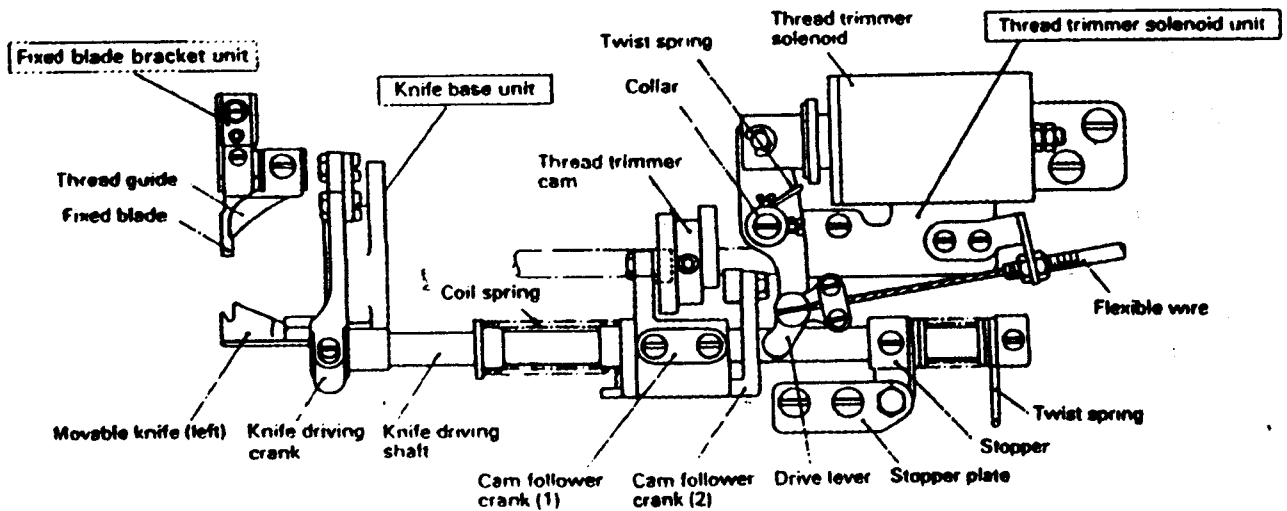
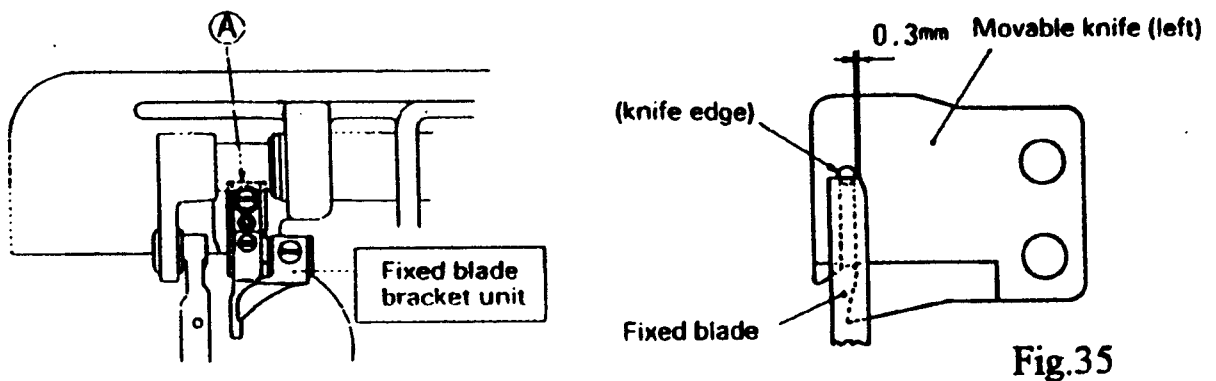

Fig.34

2) Relation between the fixed blade and movable knife (left) edge:

- (1) The standard position is illustrated as Fig.35.
- (2) The distance between the fixed blade and movable knife is 0.3mm.
- (3) The correct position of fixed blade bracket or fixed blade can be adjusted according to Fig.35.



3) Knife driving shaft:

- (1) The standard position is illustrated as Fig.36.
- (2) When assembling, the knife driving shaft must first be put through the drive arm.
- (3) Cam follower crank 1 must be positioned as illustrated to the right,

and secured on the recess located on the knife driving shaft.

(4) The stopper must be secured on the recess in such a way that the knife driving shaft is snug and smoothly rotates in the shaft direction.

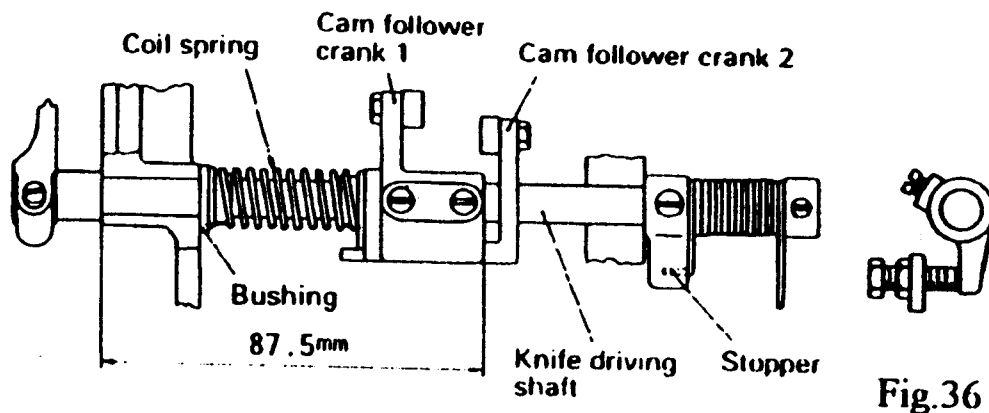

Fig.36

4) Installing the thread trimmer solenoid unit (Fig.37):

(1) Operation stroke of the thread trimmer solenoid:

- a. Standard operation stroke is 6.0mm.
- b. This stroke can be adjusted by using nut "A".

(2) Installing the unit:

- a. The unit can be mounted by using screws "B" and "C".
- b. Clearance of 1.0mm must be insured between the driving lever and cam follower crank 2 with stopper nut "A" made contact with solenoid.
- c. In such a situation, activating the solenoid should create a clearance of 0.5mm between cam follower crank 1 and 2. This situation is standard. To meet this standard, slide the solenoid mounting bracket in the direction of the arrow as illustrated, if adjustment is needed.

5) Installing the thread trimming cam (Fig.38):

(1) Face the 2nd timing mark "A" (GREEN) located on the pulley to the matching mark on the arm.

(2) With the thread trimmer solenoid activated, rotate the thread trimmer cam forward until the cam makes contact with the roller. Then, secure the cam.



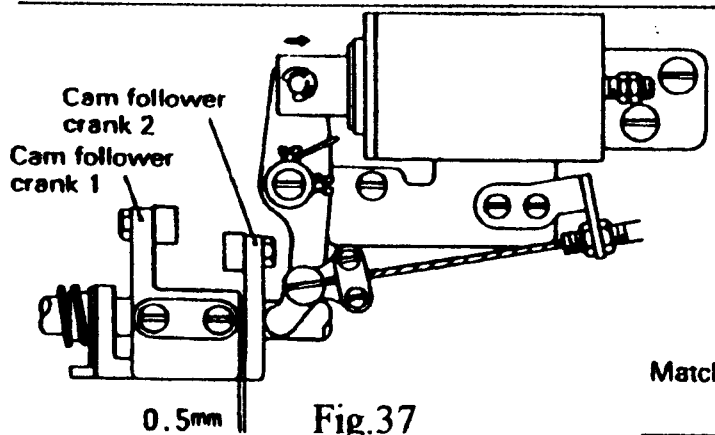
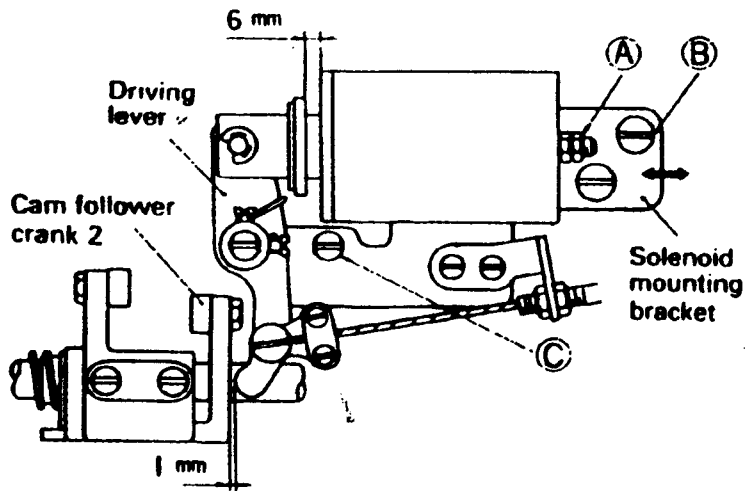

Fig.37

(3) With the thread trimmer solenoid deactivated, allow the cam follower crank 2 to return to its original position. This should create a clearance of 0.5mm-1.0mm between the cam and roller end. This distance is standard.

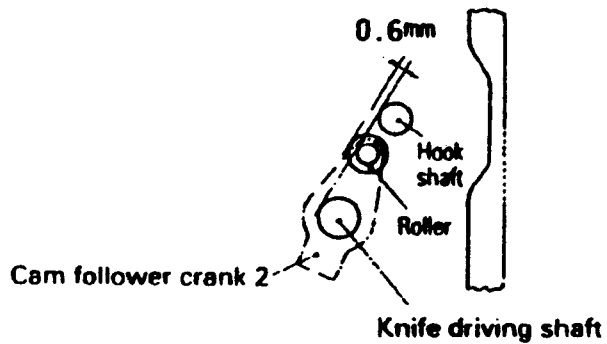
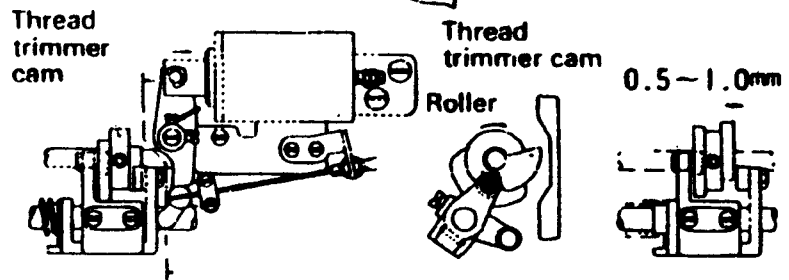
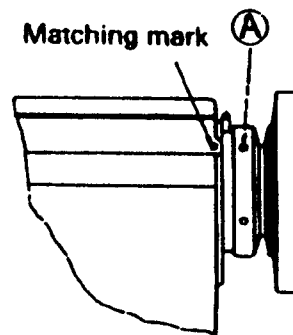

Fig.38

6) Adjustment of knife engagement (Fig.39):

(1) Position of movable knife (left) and fixed blade:

See the Fig.39, the standard distances from the needle center are 7.5mm and 5mm from the movable knife (left) and fixed blade respectively.

(2) Adjustment of knife engagement:

With the solenoid activated, turn on the machine. This rotates the thread trimming cam which rotates the movable knife (left). When the movable knife (left) has moved to its farthest distance, the standard engagement of the blade is 1.5mm-2.0mm. The engagement can be adjusted by properly mounting the drive arm.

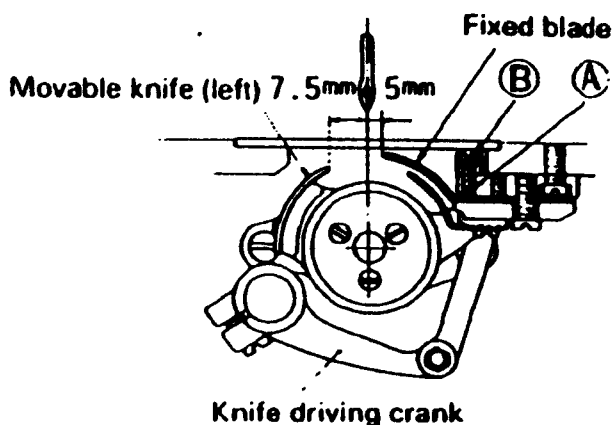

(3) Adjustment of knife engagement pressure:

a. If a thread is poorly cut, particularly when it is thick, slightly increase the engaging pressure.

This should solve the problem.

b. The engaging pressure can be adjusted in this way: Loosen lock nut "B" and adjust it by using adjusting screw "A".

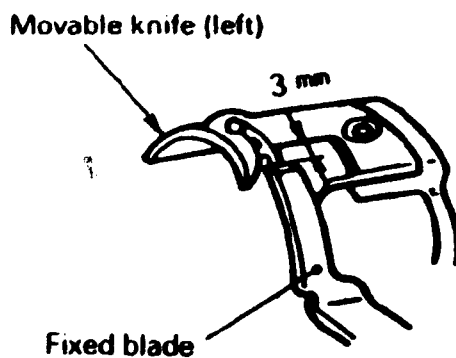
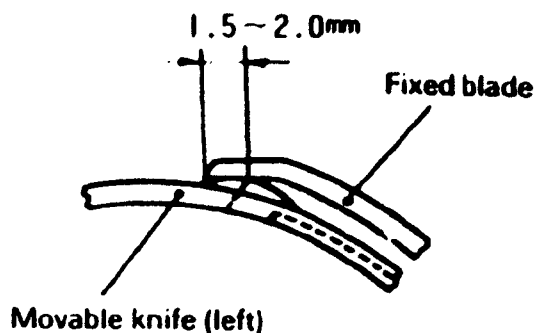
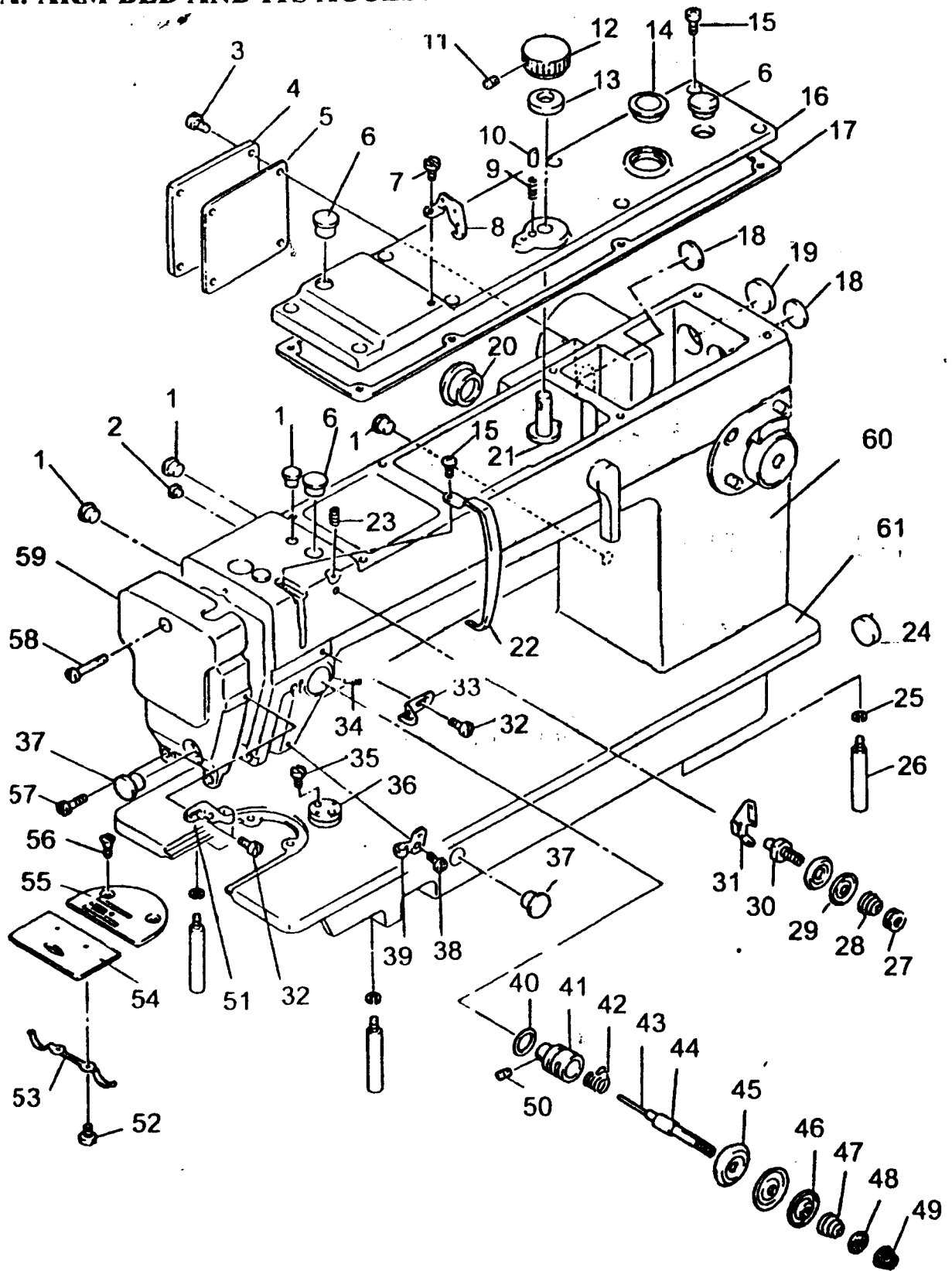

Fig.39

# A: ARM BED AND ITS ACCESSORIES



## A: ARM BED AND ITS ACCESSORIES

No.	Ref. No.	Description	Pcs.
A1	H6001001	Rubber plug	4
A2	H6001002	Rubber plug	1
A3	H6001003	Screw	4
A4	H6001004	Arm side cover	1
A5	H6001005	Gasket for arm side cover	1
A6	H6001006	Rubber plug	3
A7	H6001007	Screw	1
A8	H6001008	Thread guide	1
A9	H6001009	Coil spring for upper feed lifting	1
A10	H6001010	Stopper pin for upper feed lifting	1
A11	H6001011	Set screw	2
A12	H6001012	Dial for upper feed lifting	1
A13	H6001013	Plate for upper feed lifting	1
A14	H6001014	Oil check window	1
A15	H6001015	Screw	8
A16	H6001016	Top cover	1
A17	H6001017	Gasket for top cover	1
A18	H6001018	Rubber plug	2
A19	H6001019	Rubber plug	1
A20	H6001020	Rubber plug	1
A21	H6001021	Upper feed lifting regulator cam	1
A22	H6001022	Thread take-up cover	1
A23	H6001023	Set screw	1
A24	H6001024	Rubber plug	1
A25	H6001025	Spring washer	3
A26	H6001026	Leg	3
A27	H6001027	Pre-tension adjusting nut	1
A28	H6001028	Thread tension spring	1
A29	H6001029	Thread tension disc	2
A30	H6001030	Thread tension stud	1
A31	H6001031	Thread guide	1
A32	H6001032	Screw	2
A33	H6001033	Thread guide	1
A34	H6001034	Set screw	1
A35	H6001035	Screw	2
A36	H6001036	Cloth guide plate	1

## A: ARM BED AND ITS ACCESSORIES

No.	Ref. No.	Description	Pcs.
A37	H6001037	Rubber plug	1
A38	H6001038	Screw	1
A39	H6001039	Thread guide	1
A40	H6001040	O-ring	1
A41	H6001041	Thread tension regulator bushing	1
A42	H6001042	Thread take-up spring	1
A43	H6001043	Thread releasing pin	1
A44	H6001044	Thread tension stud	1
A45	H6001045	Thread tension disc	2
A46	H6001046	Thread tension releasing disc	1
A47	H6001047	Thread tension spring	1
A48	H6001048	Thumb nut revolution stopper	1
A49	H6001049	Thumb nut	1
A50	H6001050	Screw	1
A51	H6001051	Thread guide	1
A52	H6001052	Screw	2
A53	H6001053	Plate spring for slide plate	1
A54	H6001054	Slide plate	1
A55	H6001055	Needle plate	1
A56	H6001056	Screw	2
A57	H6001057	Screw	2
A58	H6001058	Screw	1
A59	H6001059	Face plate	1
A60	H6001060	Arm	1
A61	H6001061	Bed	1

**B: SEWING MECHANISM**

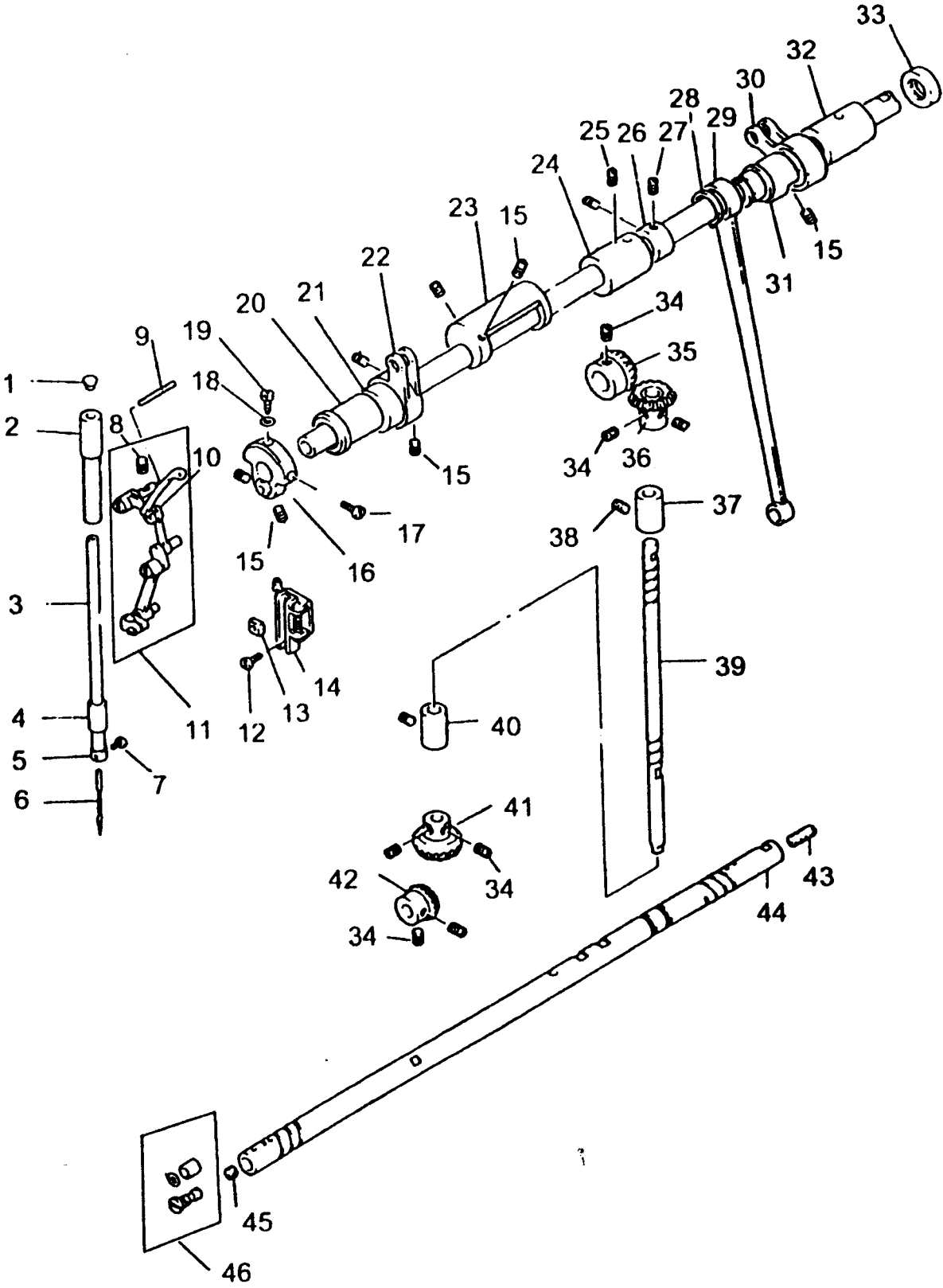

## B: SEWING MECHANISM

No.	Ref. No.	Description	Pcs.
B1	H6002001	Rubber plug	1
B2	H6002002	Needle bar bushing (upper)	1
B3	H6002003	Needle bar	1
B4	H6002004	Needle bar bushing (lower)	1
B5	H6002005	Thread guide	1
B6	H6002006	Needle	1
B7	H6002007	Set screw	1
B8	H6002008	Screw	1
B9	H6002009	Felt	1
B10	H6002010	Oil shade cap	1
B11	H6002011	Thread take-up lever assy	1
B12	H6002012	Screw	2
B13	H6002013	Slide block	1
B14	H6002014	Needle bar connecting link guide	1
B15	H6002015	Set screw	2
B16	H6002016	Needle bar crank	1
B17	H6002017	Screw	1
B18	H6002018	O ring	1
B19	H6002019	Set screw	1
B20	H6002020	Upper shaft bushing (upper)	1
B21	H6002021	Upper feed lifting cam	1
B22	H6002022	Upper feed rock crank (left)	1
B23	H6002023	Balance weight	1
B24	H6002024	Upper shaft bushing (middle)	1
B25	H6002025	Screw	1
B26	H6002026	Collar for upper shaft	1
B27	H6002027	Screw	2
B28	H6002028	C type retaining ring	1
B29	H6002029	Crank rock	1
B30	H6002030	Upper feed rock crank (right)	1
B31	H6002031	Upper feed lifting cam (right)	1
B32	H6002032	Upper shaft bushing (right)	1
B33	H6002033	Oil seal	1
B34	H6002034	Screw	8
B35	H6002035	Upper shaft gear	1
B36	H6002036	Vertical shaft gear (upper)	1

## B: SEWING MECHANISM

No.	Ref. No.	Description	Pcs.
B37	H6002037	Vertical shaft bushing (upper)	1
B38	H6002038	Screw	2
B39	H6002039	Vertical shaft	1
B40	H6002040	Vertical shaft bushing (lower)	1
B41	H6002041	Vertical shaft gear (lower)	1
B42	H6002042	Lower shaft gear	1
B43	H6002043	Rubber plug	1
B44	H6002044	Upper shaft	1
B45	H6002045	Felt	1
B46	H6002046	Oil amount adjusting pin assy	1



**C: SEWING MECHANISM & FEED ROCK LOWER SHAFT MECHANISM**

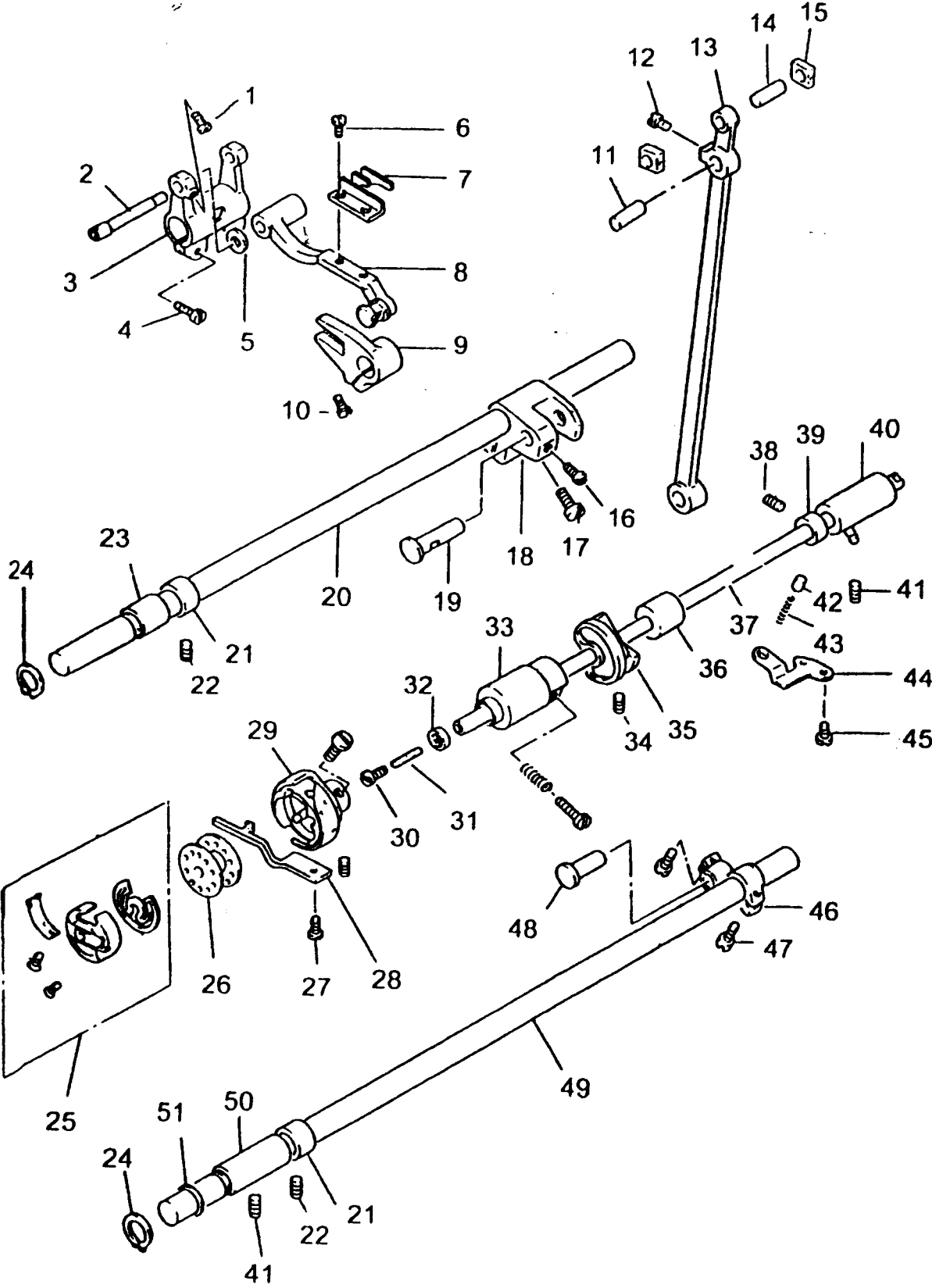

## C: SEWING MECHANISM & FEED ROCK LOWER SHAFT

No.	Ref. No.	Description	Pcs.
C1	H6003001	Screw	1
C2	H6003002	Shaft for feed bar (eccentric)	1
C3	H6003003	Feed rock shaft crank	1
C4	H6003004	Screw	2
C5	H6003005	Washer	1
C6	H6003006	Screw	2
C7	H6003007	Feed dog	1
C8	H6003008	Feed bar assy	1
C9	H6003009	Feed lifting rock shaft fork	1
C10	H6003010	Screw	1
C11	H6003011	Upper feed rock shaft	1
C12	H6003012	Screw	1
C13	H6003013	Connecting rod for upper feed	1
C14	H6003014	Upper feed rock shaft	1
C15	H6003015	Square block	2
C16	H6003016	Screw	1
C17	H6003017	Screw	1
C18	H6003018	Feed rock shaft crank (right)	1
C19	H6003019	Pin	1
C20	H6003020	Feed rock shaft	1
C21	H6003021	Collar for feed rock shaft	2
C22	H6003022	Screw	4
C23	H6003023	Bushing for feed rock shaft	1
C24	H6003024	C type retaining ring	1
C25	H6003025	Bobbin case	1
C26	H6003026	Bobbin	1
C27	H6003027	Screw	1
C28	H6003028	Hook positioner	1
C29	H6003029	Rotating hook	1
C30	H6003030	Screw	1
C31	H6003031	Oil felt for hook shaft	1
C32	H6003032	Oil seal	1
C33	H6003033	Bushing for hook shaft (left)	1
C34	H6003034	Screw	2
C35	H6003035	Thread trimmer cam	1
C36	H6003036	Bushing for hook shaft (middle)	1















































