

GLOBAL

ZZ 9567-75

LONG-ARM PATTERN ZIGZAG MACHINE

INSTRUCTION MANUAL

WWW.GLOBALSEW.COM



CONTENT

1 Operating instruction manual

| | |
|---|----|
| 1、 Safety operating guide..... | 1 |
| 2、 Operating notice..... | 1 |
| 3、 Operating condition..... | 1 |
| 4、 Chief specification..... | 1 |
| 5、 Power cable connection..... | 2 |
| 6、 Control box connection..... | 2 |
| 7、 Install belt..... | 2 |
| 8、 Install belt cover..... | 2 |
| 9、 The needle bar stop position adjustment..... | 2 |
| 10、 Operation guide (motor and control box)..... | 3 |
| 11、 To lubricate the machine..... | 3 |
| 12、 The hook lubricating condition adjustment..... | 3 |
| 13、 Time machine cleaning..... | 3 |
| 14、 Wind the bobbin..... | 4 |
| 15、 Insert the needle..... | 4 |
| 16、 Put bobbin in hook assembly..... | 5 |
| 17、 To thread upper thread..... | 5 |
| 18、 To catch lower thread..... | 5 |
| 19、 The stitch length and backstitch adjustment..... | 5 |
| 20、 The stitch width adjustment..... | 6 |
| 21、 The thread tension adjustment..... | 6 |
| 22、 The thread take up spring tension adjustment..... | 7 |
| 23、 The presser foot pressure adjustment..... | 7 |
| 24、 The gap between hook assembly and needle adjustment..... | 7 |
| 25、 The feed dog height adjustment..... | 7 |
| 26、 The feed dog obliquity adjustment..... | 7 |
| 27、 The needle punches into the center of the slot of the throat plate position adjustment..... | 8 |
| 28、 The needle base point offset adjustment..... | 9 |
| 29、 Install synchronous belt..... | 9 |
| 30、 Timing between needle and feed dog motion..... | 9 |
| 31、 The forward/backward stitch length error adjustment..... | 9 |
| 32、 The position between hook and opener motion adjustment..... | 9 |
| 33、 The thread trimming device adjustment..... | 10 |

1. Safety operating guide

- 1) When turning the power on, keep your hands and fingers away from the area under the needle and around the pulley.
- 2) Power must be turned off when the machine is not used or when the operator leaves his/her seat.
- 3) Power must be turned off when incline the machine head, install/remove the belt or move machine.
- 4) Don't place finger, hair, shaft etc. near pulley, belt, wheel and motor in order to avoid injury.
- 5) Don't insert finger into the thread take up lever guard cover, keep your hands and fingers away from the area under the needle and around the pulley when the machine is in operation.
- 6) Don't operate the machine without the safety devices if the belt cover or eye guard are installed.

2. Operating notice

- 1) Don't operate the machine if the oil tank without full oil.
- 2) The machine adopt semi-automatic lubricating mode. Don't operate the machine before lubricating.
- 3) Check the rotation direction of pulley when firstly start new machine. (The pulley should rotate in counterclockwise when viewed from pulley)
- 4) Check the voltage and phase. (Single or three whether is corresponds with the data in motor nameplate)

3. Operating condition

- 1) Avoid using machine at abnormally high temperature (40°C or higher) or low temperature (5°C or lower). Otherwise machine failure may result.
- 2) Avoid using machine in dusty condition.

4. Chief specification

| Model | | ZZ 9567-75 | ZZ-9567-75 AUT |
|---------------------------|--------------|---|-------------------|
| Specification | | | |
| Max sewing speed (rmp) | | 2800 | |
| Stitch length (mm) | | 0-5 | |
| Stitch width (mm) | | 0-10 | |
| Needle bar stroke (mm) | | 36 | |
| Take-up lever stroke (mm) | | 82 | |
| Needle | | DPx17 Nm90-120 | |
| Feed dog height (mm) | | 1.2 | |
| Presser root lift | height (mm) | 8 | |
| | By hand (mm) | 10 | |
| Hook | | Semi-lubricating and trinal thread capacity | |
| Lubricating mode | | Semi-automatic lubricating | |
| Trimming device | | Without | With |
| Motor | | Clutch motor 370W | Servo motor 550W |

5. Power cable connection

- 1) When connecting the power cable to control box, it should confirm the connector type and machine direction firstly and then plug the connector into proper receptacle completely.
- 2) Rotary direction: Please refer the instruction book of conected motor if it needs to change the rotary direction of motor.

6. Control box connection

The control box should be connected as shown in fig.1.

Note:

- (1) Be sure to turn the power switch off for safety before connecting or disconnecting the connector.
- (2) Machine type must suit for control box of motor.

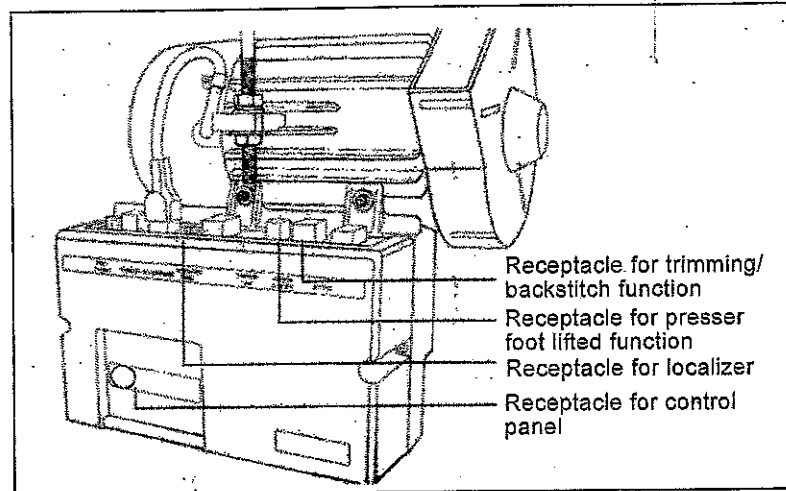

Fig.1

7. Install belt(Fig.2)

- 1) Use V-belt which special for sewing machine.
- 2) To adjust the tension of belt. Change the height of motor through turn the tension adjustive nut. It is ok if the belt can be sink inside with 15mm when pressing the center position of belt surface. Lacking tension will cause unstable running speed of machine, or needle stand at wrong stop position when machine in middle/slow running condition. Excessive tension will cause the motor bearing be damaged.

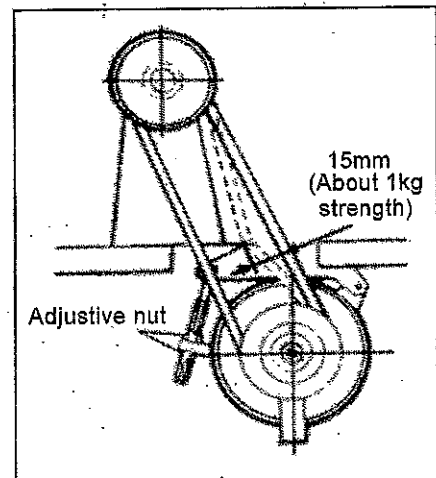

Fig.2

8. Install belt cover

It must install belt cover for machine head and motor for safety.

9. The needle bar stop position adjustment

Note: It adopts outside localizer, please refer the instruction book of conected motor for the adjustment method.

1) "Up" Position

When the pedal is kicked down by heel, the machine should stop at "Up" position, i.e. the highest position of take-up lever.

2) "Down" Position

When the pedal is stand at middle position, the machine should stop at "Down" position, i.e. the needle bar raises 3mm from its lowest position.

10. Operation guide (motor and control box)

- 1) Keep foot away from pedal when turn on/off the power. Power must be turned off when the operator leaves his/her seat.
- 2) The detent can't work when the power is interrupted or power failure occurs during the machine operation.
- 3) Keep the control box cover is closed during operation in order to avoid accidental operation since the dust come into control box.
- 4) Must use multimeter to check control loop circuit in order to protect the semiconductor parts.
- 5) Power must be turned off when incline machine head only or touch needle.
- 6) Must use earthing cable (with yellow/green color) to connect motor.
- 7) When check the inter circuit, it must turn off the power firstly and then open the front cover.
- 8) It must wait 10 minutes after turn off the power due the high voltage in box. (It is very importance to release the inside energy.)
- 9) Keep motor away from much noise area such as high frequency joint area when use it

11. To lubricate the machine

Clean the machine completely before operate it daily, and check the oil quantity of hook oil tank. Then inject oil as arrow shows in fig.3 and fig.4, start operation of machine.

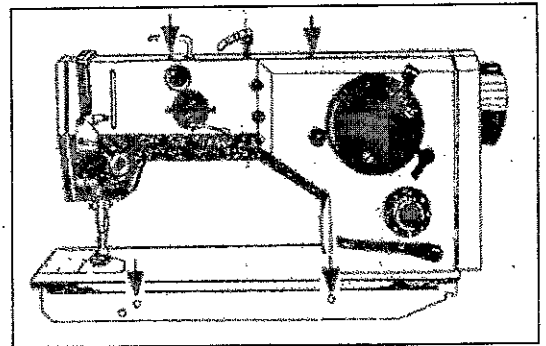

Fig.3

12. The hook lubricating condition adjustment(Fig.4)

To adjust hook lubricating through screw A which site before oil tank of hook.

- 1) The oil quantity is lowest when screw A was turned with clockwise and the arrow points to "0" position.
- 2) The oil quantity is highest when screw A was turned with anticlockwise and the arrow points to "MAX" position.

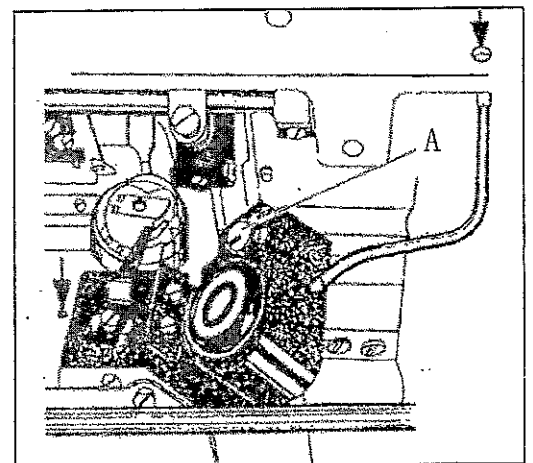

Fig.4

13. Time machine cleaning

The hook, feed dog and other parts of machine should be cleaned daily, and drop two or three coal oil into hook and other place that need to be lubricated. Clean all the spilth after ending of highest speed operation of machine, then lubricate the machine with oil. The clean work must be insisted every day. (Especially the machine worked one week, the clean work is very importance. Or the spilth will affect the sewing capability and rust hook and machine. It should to take away bobbin from hook before cleaning.)

Maintenance of motor: Clean dust of the motor cover each one or two month. (More dust or sundries of motor cover will make it too heat.)
 Maintenance of control box: Clean dust of the connector. (It will affect accidental operation if there is more dust on the connector.)

Warning:

Before proceeding to clean and librating the machine, be sure to switch off all switches and hold your feet away from the machine stand pedal in order to avoid accidental machine start by pedal actuation.

14. Wind the bobbin(Fig.5)

1) Inside winder (Fig.5)
 Pass the thread through the thread guide (6) from the thread stand, wind it few times anticlockwise on the bobbin and put the bobbin on the winder shaft (1). Switch on the motor and depress the treadle lightly to start the machine and by this winder as well. The winding amount (See Fig.6) is 80% of full capacity. It can be adjusted by loosening the screw (4) of the control lever (5) mounted on the disconnecting pin (3). When the winding is completed, using the knife mounted in the spring (2) cut off the thread end.

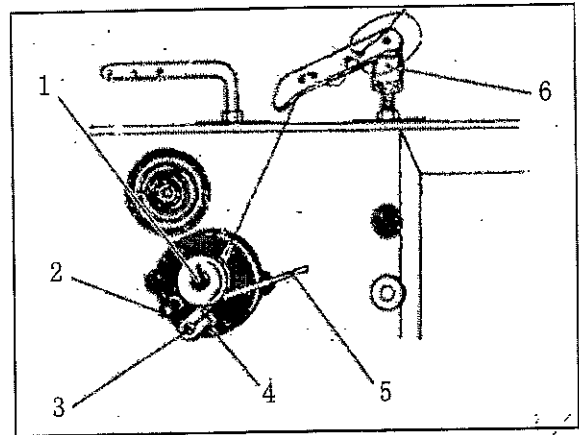

Fig.5

2) Outside winder (Fig.6)

Thread tension: Slack winding is recommended for polyester and nylon thread.
 Amount of wound thread: Move the thread guide toward smaller diameter of wound thread layer.
 Capacity of wound thread: Loosen the adjust screw to decrease the amount of wound thread. Vice versa.

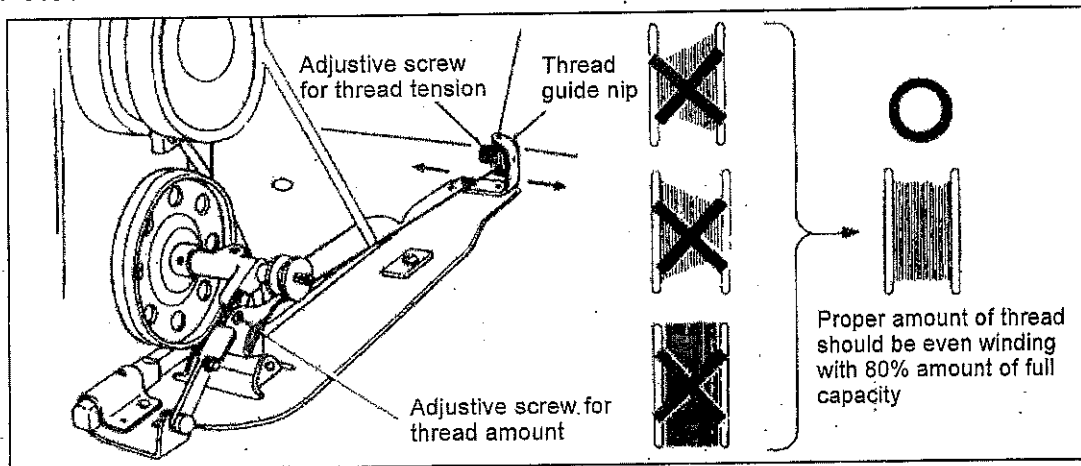

Fig.6

15. Insert the needle(Fig.7)

Please use DPx17 Nm90-120 needle, the thickness of needle should be decided according to the thickness of sewing material & thread. When insert the needle, rotate the hand wheel until the needle bar has reached its top position, loosen the screw on the lower part of the needle bar and insert the needle. Be sure that the long groove of

the needle directed toward the operator and check whether the needle shank has reached the bottom of the needle hole. Fix the needle by tightening the screw.

Warning!

Before insert the needle, be sure to switch off the main switch.

If the terylene thread is broken when backstitch, turn the needle groove to right, maybe can avoid this condition. Normally avoid letting the needle groove face to left.

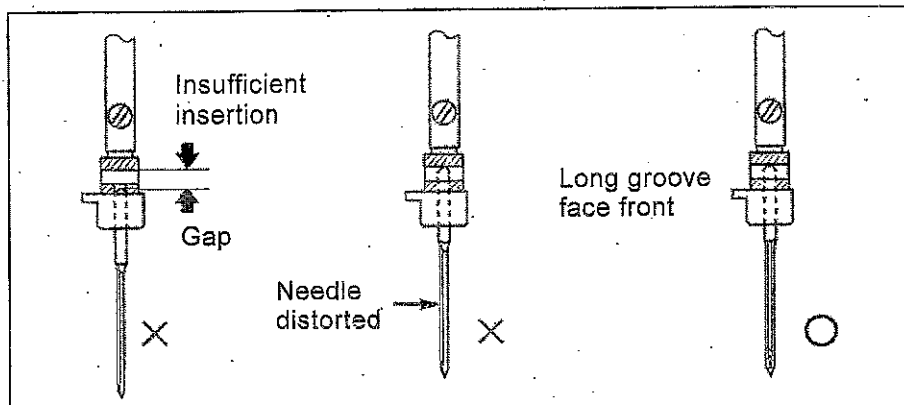

Fig.7

16. Put bobbin in hook assembly

Bring out 5mm lower thread from bobbin. Turn the thread winding direction to right. Insert the bobbin case with the bobbin into the hook. To prevent the bobbin from falling out of the case, while being inserted into the hook, tilt the lock fixing the bobbin in the case. With your thumb, push the bobbin case in until you hear a short distinct sound. The correct position of the bobbin case in the hook signaled by this sound is very important, because otherwise a needle rupture or another breakdown could occur at the following machine start.

17. To thread upper thread(Fig.8)

Let the take up lever at its highest position. Then threading as shown in Fig.8.

Unwind a sufficient portion of thread, and pass it through the thread guide (1) and (2), then lead it through the tension disc (6) and thread take up spring (5), thread guides (7), (4) and (3) into the thread take-up lever. Then downwards through the thread guide (4) and the lower thread guide (8) to the thread guide (9) on the needle bar, and to the needle. Insert it into the needle ear from the front side to the rear side.

18. To catch lower thread

Hold the end part of upper thread by left hand; turn the pulley wheel slowly by right hand. The upper thread was being took up and lead the lower thread out. Make them coordinative, then pass them through the underside of presser foot, put them behind the position of needle. Put some materials under presser foot before start sewing. The take up level must at its highest position when start and end the sewing.

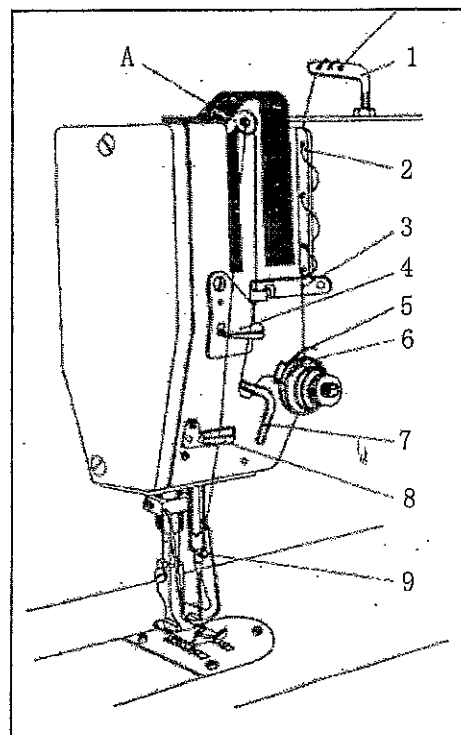

Fig.8

19. The stitch length and backstitch adjustment (Fig.9, Fig.10)

- 1) The stitch length can be adjusted by turning the knob (4) provided on the column of the machine arm, from 0 to 5mm. By turning it in the sense of the arrow "A", you increase the stitch length. By turning it in the sense of the arrow "B", you decrease it.
- 2) Depress the backstitch hand lever (1) can proceed backstitch.
- 3) Depress the backstitch button as shown in Fig.10 can proceed backstitch.

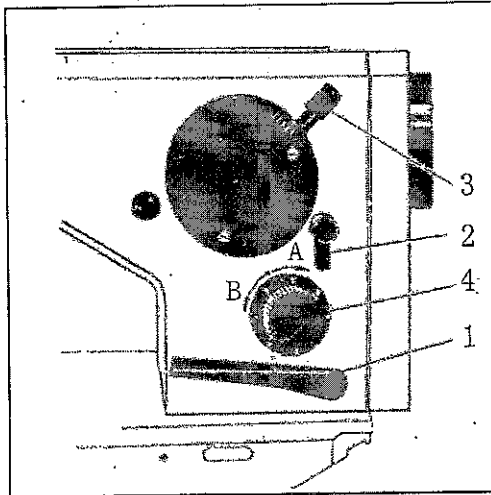

Fig.9

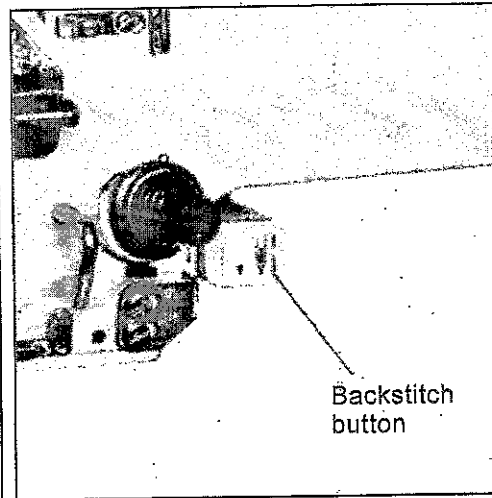

Fig.10

20. The stitch width adjustment (Fig.9)

Before adjustment of the stitch width, the machine must be stopped and the needle outside the sewn work. Release the locking spanner (2) (anticlockwise) and then adjust stitch width through the spanner (3). By displacing the lever to the right can increase the zigzag stitch width. By displacing it to the left can decrease it. Lock the locking spanner (2) after the adjustment is well.

21. The thread tension adjustment (Fig.11,12,14)

The tension of upper and the lower thread must be interrelated that the stitch forming and the sewn material. (Fig.12)

- 1) To adjust the upper thread tension according to the lower thread tension. Turn the tension adjustable nut in clockwise to increase the tension, or inversely, to decrease it.
- 2) To adjust the lower thread tension by turning adjustable screw A in Fig.14.
- 3) It can adjust the take up spring to adjust upper thread tension for special sewn material and thread.

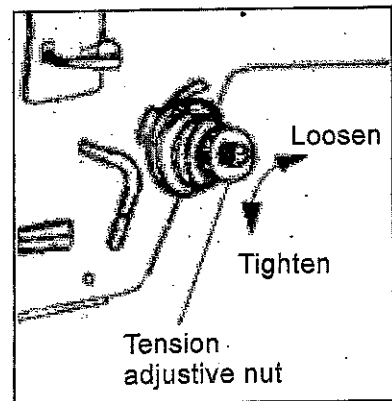

Fig.11

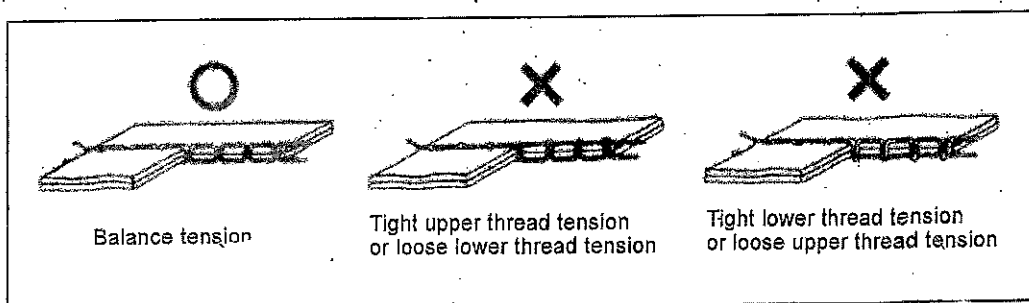

Fig.12

22. The thread take up spring tension adjustment(Fig.13)

Loosen thread tension assembly screw (1), take away the thread tension assembly from machine to adjust take up spring (4). Firstly loosen the screw (2) of bushing (3), and then adjust the angle position of lever (5). Turn it to left can increase the elasticity of spring, or inversely, to decrease it:

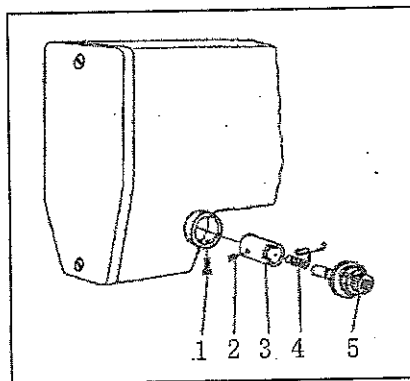

Fig.13

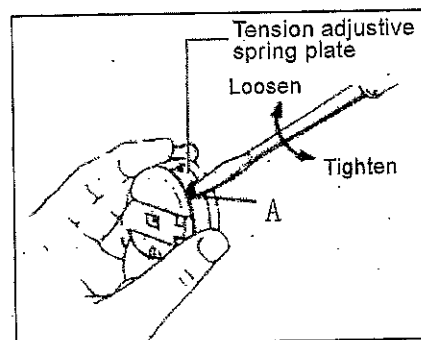

Fig.14

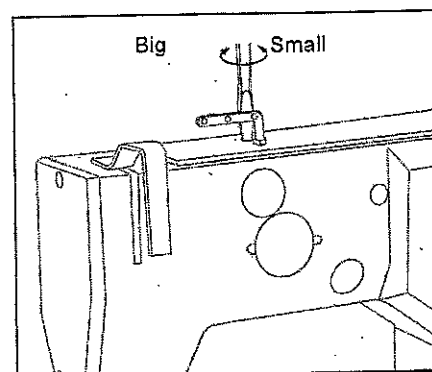

Fig.15

23. The presser foot pressure adjustment (Fig.15)

1) To adjust the presser foot pressure according to the sewn material.

2) Adjustment as shown in Fig.15.

3) The pressure of sewing must to be adjusted as its min. value. But at same time, the pressure of pressure foot must be sufficient to ensure reliable and continuous feeding even at the top speed.

24. The gap between hook assembly and needle adjustment(Fig.16)

Adjust the stitch forming width to zero and turning round the hand wheel towards the machine, when the needle goes up 2mm from the lowest position, the position of needle hole should be lower 1.6mm than hook top. The hook top position should be accordant with the centerline of needle and the gap from hook top to needle slot bottom should be 0.05mm.

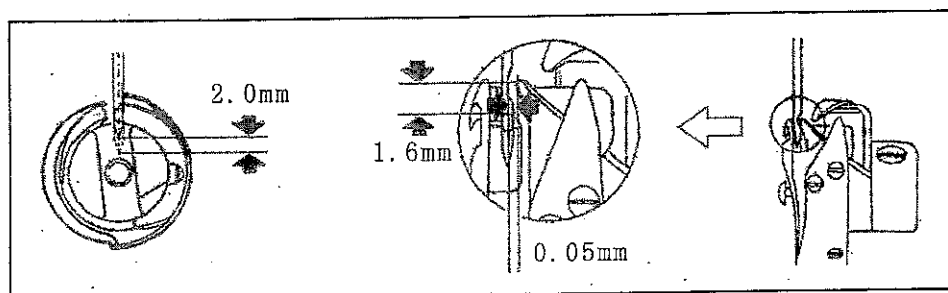

Fig.16

25. The feed dog height adjustment (Fig.17)

The height of feed dog should be higher 1.0mm than needle plate. It is the standard for leaving factory. The height of feed dog can be adjusted to 0.8-1.2mm according to sewn material. To adjust it, turn pulley wheel to the highest position of feed dog, loosen the screw (2) of the lifting lever (8) on the shaft (6), adjust it to the required height of the feed dog and retighten the screw.

26. The feed dog obliquity adjustment(Fig.17)

The standard position of feed dog is horizontal. It can be adjusted according to sewn material. To adjust it, loosen the screw (1) of the feeding lever (9) on the shaft (7), adjust the rear part of feed dog by correspondingly adjusting the position of eccentric pin (5), adjust it to the required height of the feed dog and retighten the screw.

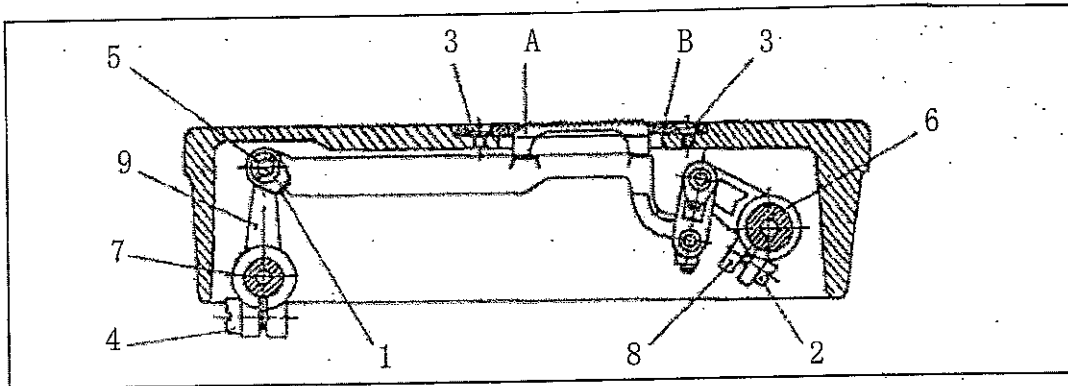

Fig.17

27. The needle punches into the center of the slot of the throat plate position adjustment (fig.5)

Adjust the stitch to the zero width and turn the pulley wheel until the needle reaches its bottom position. At the same time, the needle should be in the center of the needle plate slot both longitudinally and transversely.

1) The needle punches longitudinally into the center of the needle plate slot position adjustment (Fig.18)

Screw out the two screws of the panel, loosen the securing screws (1) and (2), and finely adjust the position of the screw (3) both on the front and on the rear side of the machine arm so as to set the needle longitudinally into the center of the needle plate slot. Retighten the screws (1) and (2) and mount the panel.

To observe: When tightening the adjustive screw for adjusting the needle position, do not tighten them completely but leave a movement space between them in order not to obstruct the transverse movement of the needle bar bracket required for stitch.

2) The needle punches transversely into the center of the needle plate slot position adjustment (Fig.19)
Adjust the stitch to the zero width and turn the pulley wheel until the needle reaches its bottom position. Screw out two screws (2) of stitch width indicating dial (1) and take away the dial (1). Loosen slide block screw(3), adjust the needle punches position through moving the slide block up and down. Retighten the screws (3) and mount the dial after the adjustment is well.

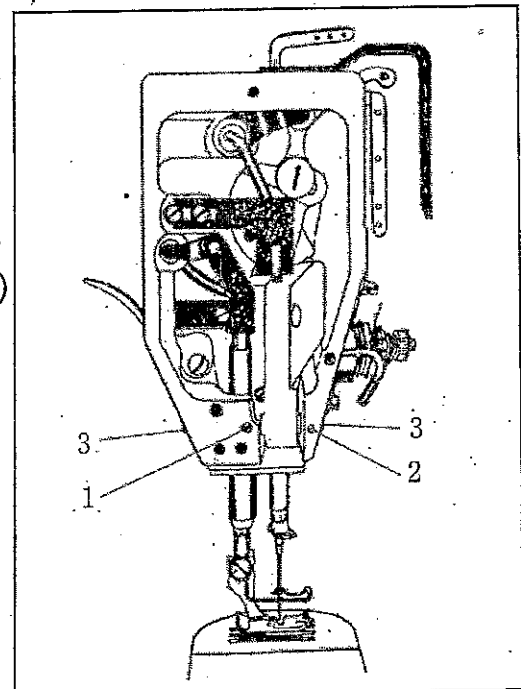

Fig.18

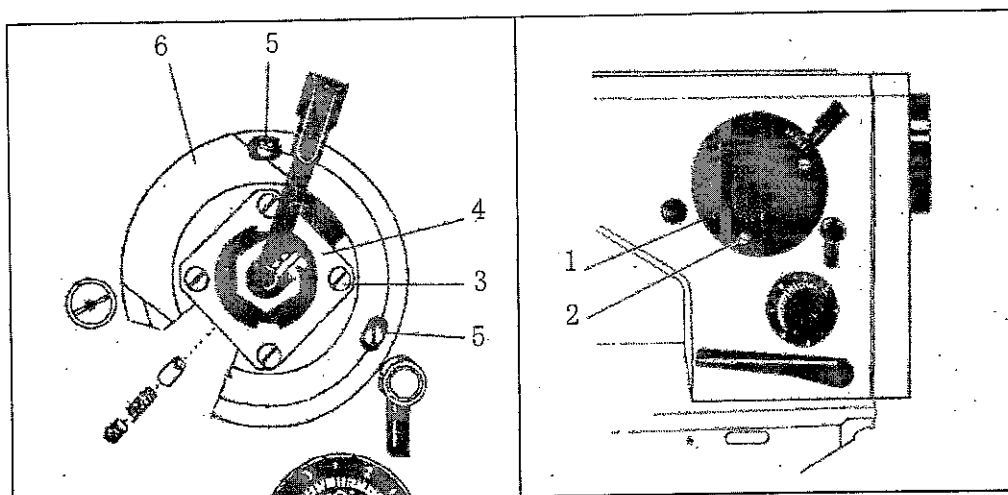

Fig.19

28、 The needle base point offset adjustment(Fig.19)

It needs to adjust the needle base point offset if the stitch forming doesn't the straight line when straight sewing. The adjustive method as below:

- 1) Turn the stitch width to zero.
- 2) Screw out two screws (2) of stitch width indicating scale (1) and take away the dial (1), loosen the turntable screw (5).
- 3) To adjust the needle base point offset by turning the turntable (6).
- 4) Retighten the turntable screw and mount the dial after the adjustment is well.

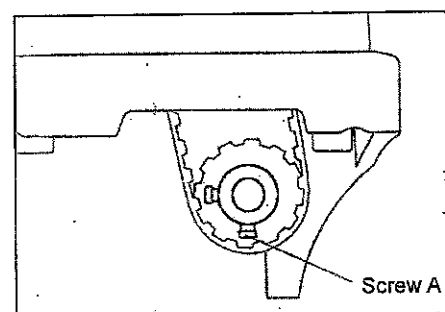

Fig.20

29、 Install synchronous belt(Fig.20)

Remount the synchronous belt according to following method:

- 1) Turn pulley wheel to the highest position of feed dog.
- 2) Lean the machine head backward. Turn the synchronous pulley of lower shaft, amount the belt when the first screw A face downwardly

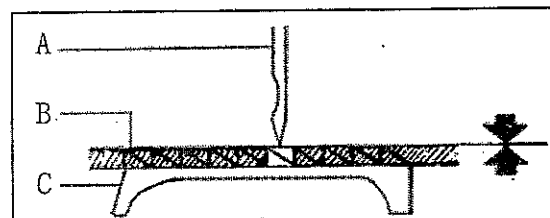

Fig.21

30、 Timing between needle and feed dog motion(Fig.21,22)

When needle point A reaches needle plate top surface B, feed dog surface C should be keep accordant on height (Fig.21) with needle plate top surface. It is the standard synchronous relationship. Adjustive method as below:

- 1) Orientation of lifting feed dog cam: Lean the machine head backward, Loosen screw(5), press lifting feed cam (6), turn pulley lightly, retighten the screw (5) when the angle becomes 90° between the orientation mark point of lifting feed cam with the groove of feed cam (7).
- 2) Loosen the synchronous pulley screw of lower shaft, turn the pulley in machine rotation direction till the needlepoint move downward to touch the top surface of needle plate. Then turn lower shaft in machine rotation direction, retighten.

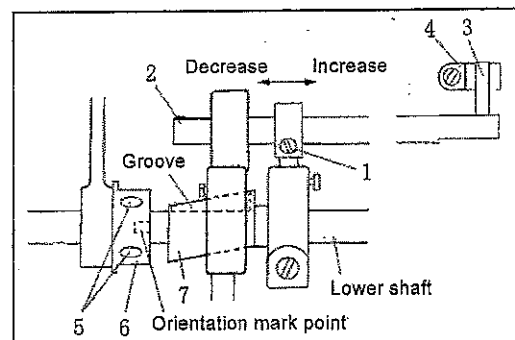

Fig.22

the synchronous pulley screw when feed dog surface keep accordant on height with needle plate top surface.

31、 The forward/backward stitch length error adjustment(Fig.22)

- 1)Adjust the forward/backward stitch length error through to adjust the position of the backstitch block on backstitch connection shaft.
- 2)Lean the machine head backward, loosen backstitch block screw (1). At same time, press backstitch pin (3) of backstitch connection shaft (2) in order to avoid it fall off backstitch control lever crank (4).
- 3)Backstitch length will be increased when remove backstitch block to right, and it will be decreased when remove backstitch block to left.
- 4)Retighten backstitch block screw (1) after the adjustment is well.

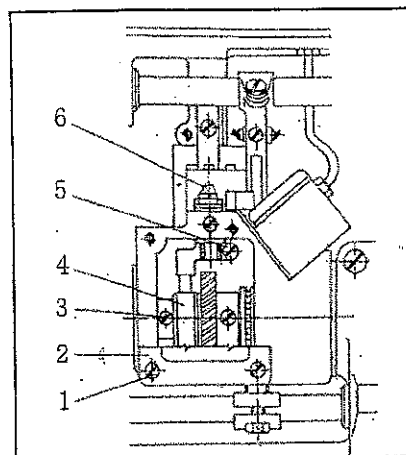

Fig.23

32、 The position between hook and opener motion adjustment(Fig.23)

- 1)Lean the machine head backward, screw out the bottom cover screw (1) of hook saddle, open bottom cover (2).
- 2)Put the needle bar to its lowest position.
- 3)Loosen thread finger cam screw (3), adjust thread finger cam (4), make thread finger site on the nearest position of hook, and then retighten thread finger cam screw.
- 4)Loosen hook opener screw (5), adjust the distance between thread finger and hook is 0.3-0.4mm.

33、 The thread trimming device adjustment(Fig.24)

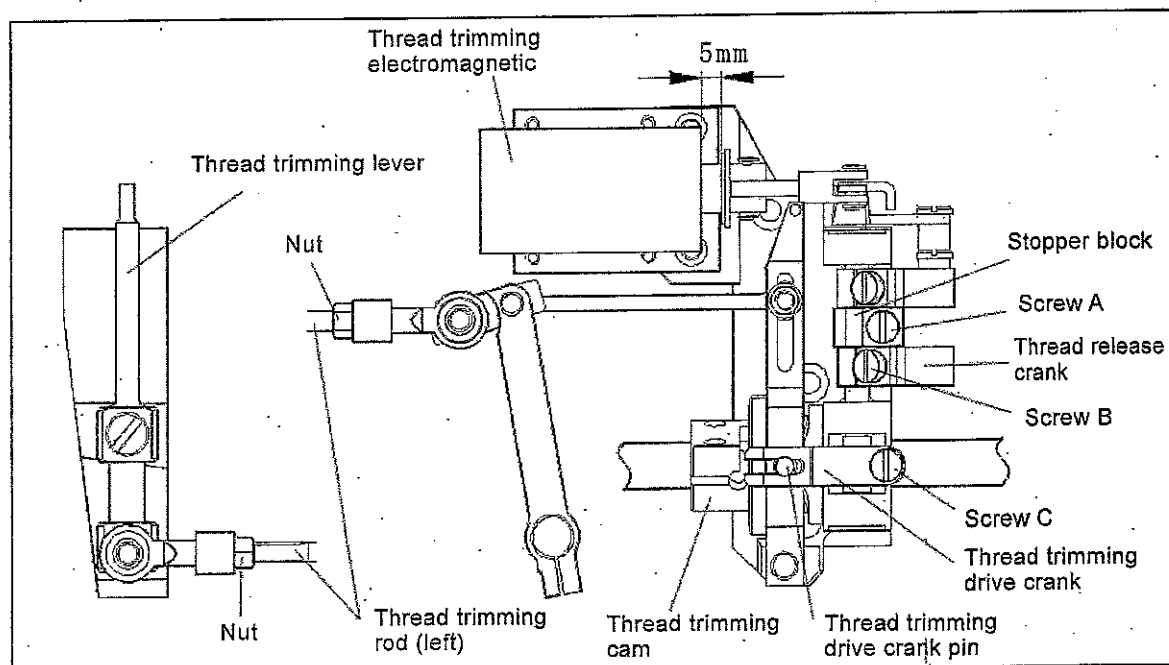

Fig.24

1)Adjustment of thread trimming electromagnetic stroke

A. The standard stroke is 5.0mm.

B. To adjust thread trimming electromagnetic stroke through to adjust the screw A of

stopper block.

2) Adjustment of thread trimming cam

A. Turn pulley till the needle to its lowest position.

B. Press the thread trimming drive crank, put the thread trimming drive crank pin into groove of thread trimming cam.

C. Turn pulley, adjust thread trimming cam till the movable knife start to move and the take up lever start to lift from its lowest position.

3) Adjustment of gap between thread trimming drive crank pin and thread trimming cam (Fig.25)

A. Turn pulley till the needle to its lowest position.

B. Loosen screw C of thread trimming drive crank, put the thread trimming drive crank

pin into groove of thread trimming cam.

C. Adjust the distance between the surface of thread trimming drive crank pin with the bottom of thread trimming cam groove is 0.5mm, retighten screw C of Thread trimming drive crank.

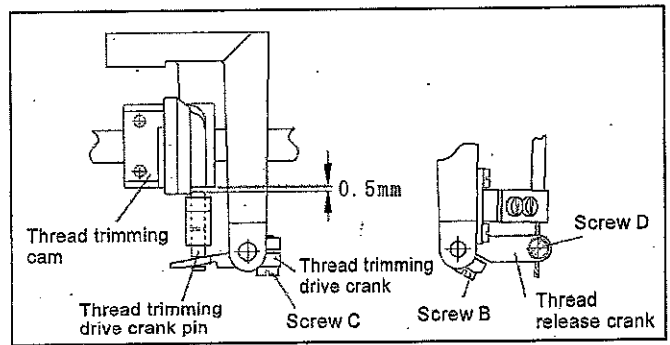

Fig.25

4) Adjustment of movable knife position (Fig.26)

A. Loosen two nuts of thread trimming rod (left).

B. To adjust the thread trimming rod (left), make the distance between the acclivitous forepart surface of movable knife with the forepart of fixed knife is 0-0.5mm, then retighten nut.

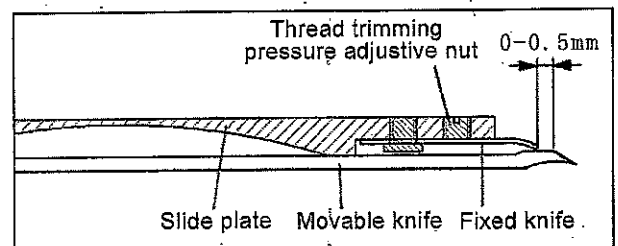

Fig.26

5) Adjustment of pressure of movable knife and fixed knife (Fig.26)

A. Turn the thread trimming pressure adjustive nut of slide plate to adjust the mesh power

of movable knife and fixed knife.

B. To confirm the thread trimming whether is sharp by moving the movable knife after ending adjustment.

To observe: The more mesh power will bring large operation moment and failure trimming, so it should to be adjusted to its minimum.

6) Adjustment of releasing gap of thread tension disc (Fig.25)

A. Turn pulley till the needle to its lowest position.

B. Press the thread trimming drive crank, put the thread trimming drive crank pin into groove of thread trimming cam.

C. Turn pulley till the take up lever to its lowest position. Here the releasing gap of thread tension disc should be its maximal.

D. The ringent degree can be adjusted through thread release crank and release soft-shaft connection. During adjustment, loosen the screw D of release soft-shaft connection and shrink the flexible wire.

Adjusting step to change cam of

patterns zigzag sewing machine

一、Change cam

- 1、Loose nut(01), take down patterns cam(03);
- 2、Screw off screw(30) with screw driver, take down cover(29);
- 3、Fit the cam which need to be changed on turbine shaft(05) (pay attention the locating pin hole should aim to the locating pin of turbine shaft), also pull the swing needle crank assy.(21) slightly, make roller(19) of swing crank come into patterns cam groove; then fit on washer\ nut and screw up it. Turn drive wheel, the machine should be operated smoothly.
- 4、Fit on cover(29) and screw up its screw.

二、Adjust swing needle time difference

Due to change different patterns cam, the needle swing time will be changed and it should difference, please adjust it as following steps:

- 1、Screw out up cover screw, take down up cover;
- 2、Loose 4pcs worm lever tighten screw(15), rotate the up shaft to a certain angle and screw up 1pc screw(15); turn drive wheel and observe needle; at this time the needle should stop its down movement when its point away 8mm from needle plate.;
- 3、Adjust it repeatedly and screw up 4cs screw(15) when it meets requirement, pay attention the worm lever surface should adjoin surface of ring(12);
- 4、Fit on up cover and screw up its screw.

三、Adjust clearance of worm wheel and worm lever

The worm wheel and worm lever will create clearance after machine be used some time, please adjust it as following steps:

- 1、 Screw out up cover screw, take down up cover;
- 2、 Screw out screw(15) of ring (14), remove ring(14) to left;
- 3、 Screw out 4pcs worm lever tighten screw(15), remove worm lever(16) to left slowly; try to reduce the clearance between worm lever and worm wheel ; then screw up tighten screw(15); turn drive wheel, the machine should be operated smoothly;
- 4、 Screw up screw and let ring to left and adjoin worm lever;
- 5、 Fit on up cover and screw up its screw.

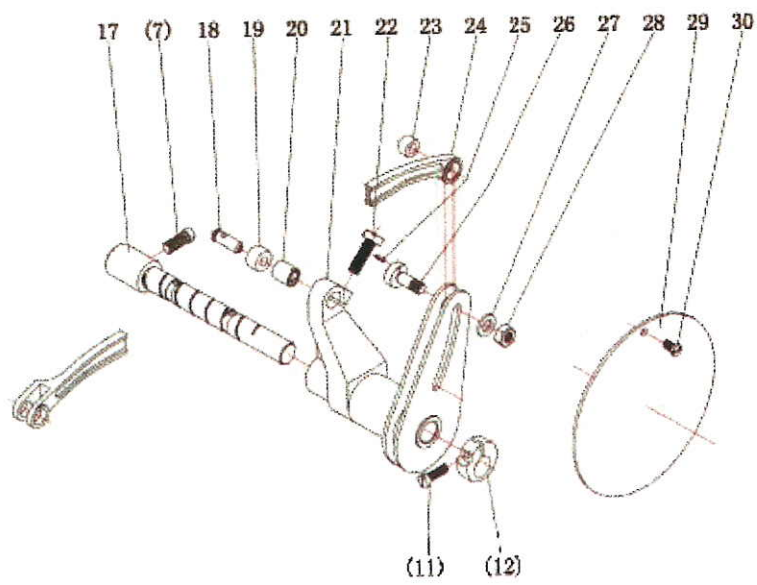
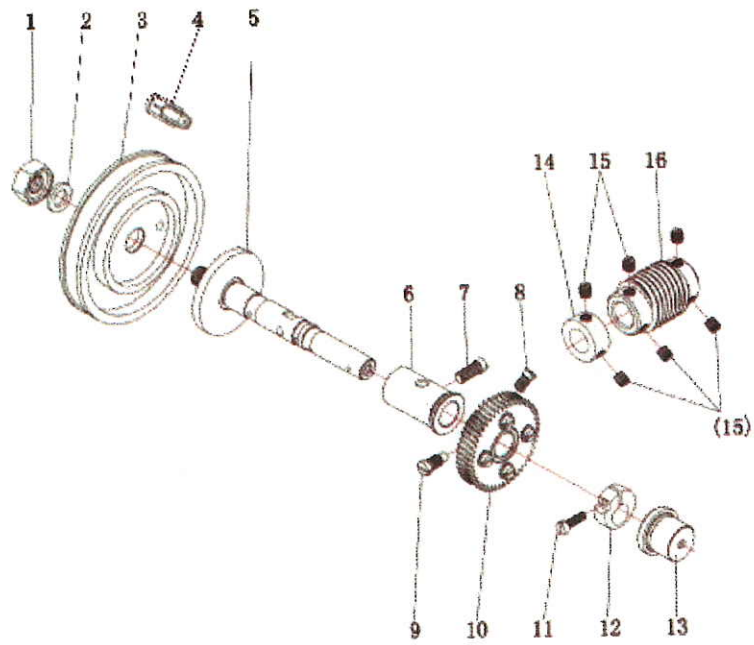

The cams for decorative seams are quickly and easily exchangeable.

Musterkurven
Pattern cams

Artikel-Nr.
Article-No.

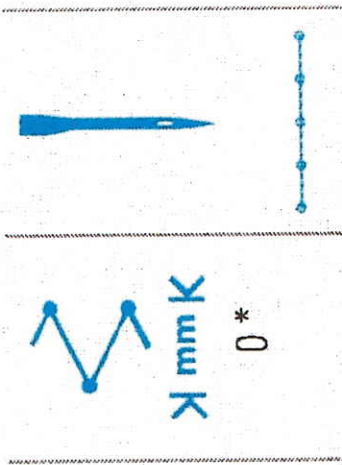









70206059

* = zur Maschinenjustierung

* = for machine adjustment

Musterkurven
Pattern cams

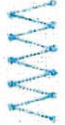
Artikel-Nr.
Article-No.

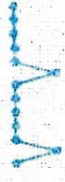
| | |
|---|---|
|  |  |
| mm K | |
| 4,5 - 10 |  |
| 3,5 - 6 |  |
| 4 - 10 |  |
| 2 - 5 |  |
| 3,5 - 6 |  |
| 4,5 - 10 |  |
| 4,5 - 10 |  |
| 3,5 - 6 |  |

70206060

70206064

70206066

70206067

70206069

70206070

70206071

70206072

