

GLOBAL

LP9915L LP9915R

INDUSTRIAL SEWING MACHINE

High-Post Bed

Single-Needle

Lockstitch

Compound-Feed

Variable speed control

INSTRUCTION MANUAL

PRECURTIONS BEFORE STARTING OPERATION

1. Safety precautions

- 1) When turning the power on, keep your hands and fingers away from the area around/under the needle and the area around the pulley.
- 2) Power must be turned off when the machine is not used, or when the operator leaves his/his seat.
- 3) The power must be turned off before tilting the machine head, installing or removing the "V" belt, adjusting the machine, or when replacing.
- 4) Avoid placing fingers, hairs bars etc. nears the pulley, "V" belt, bobbin winder pulley, or motor when the machine is operation. Injury could result.
- 5) Do not insert fingers into the thread take-up cover, under/round the needle, or pulley when the machine is in operation.
- 6) If a belt cover, finger guard, and/or eye guard are installed, do not operate the machine without these safety devices.

2. Precaution before Starting Operation

- 1) If the machine's oil pan has an oil sump, never operate the machine before filling it.
- 2) If a drop oiler lubricates the machine, never operate the machine before lubricating.
- 3) When a new sewing machine is first turned on, verify the rotational direction of the pulley with the power on.
(the pulley should rotate counterclockwise when viewed from the pulley.)
- 4) Verify the voltage and (single or three) phase with those given on the motor nameplate.

3. Precaution for Operating Conditions

- 1) Avoid using the machine at abnormally high temperature (35°C or higher) or low temperature (5°C or lower). Otherwise, machine failure may result.
- 2) Avoid using the machine in dusty conditions.
- 3) Avoid using the machine in areas where too much electrical noise, resulted from the high-frequency welder and others, is generated.

----- CONTENTS -----

PREPARATION FOR OPERATION

..... 1

CAUTIONS ON USE

- | | |
|--------------------------|---|
| 1. Oiling (1) | 2 |
| 2. Oiling (2) | 2 |
| 3. Oiling condition | 3 |
| 4. Cautions on operation | 3 |

OPERATION

- | | |
|---|----|
| 1. Installation of needles | 4 |
| 2. Winding of bobbin thread | 5 |
| 3. Selection of threads | 6 |
| 4. Threading of needle threads | 6 |
| 5. Adjustment of feed (stitch) length and stitch reversing (touch-back) | 7 |
| 6. Balance of thread tension | 7 |
| 7. Needle thread tension | 8 |
| 8. Adjustment of presser foot pressure | 8 |
| 9. Timing between rotating hook motion and needle motion | 9 |
| 10. Adjustment of feed dog height | 10 |
| 11. Relationship between rotating hook motion and take-up lever motion | 11 |
| 12. Relationship between hook motion and opener motion | 12 |
| 13. Safety clutch device | 13 |
| 14. Upper feed adjustment (needle side) | 14 |
| 15. Outside presser foot and inside presser vertical stroke adjustment | 15 |
| 16. Adjustment of forward/backward stitch length | 15 |

Specifications 16

PREPARATION FOR OPERATION

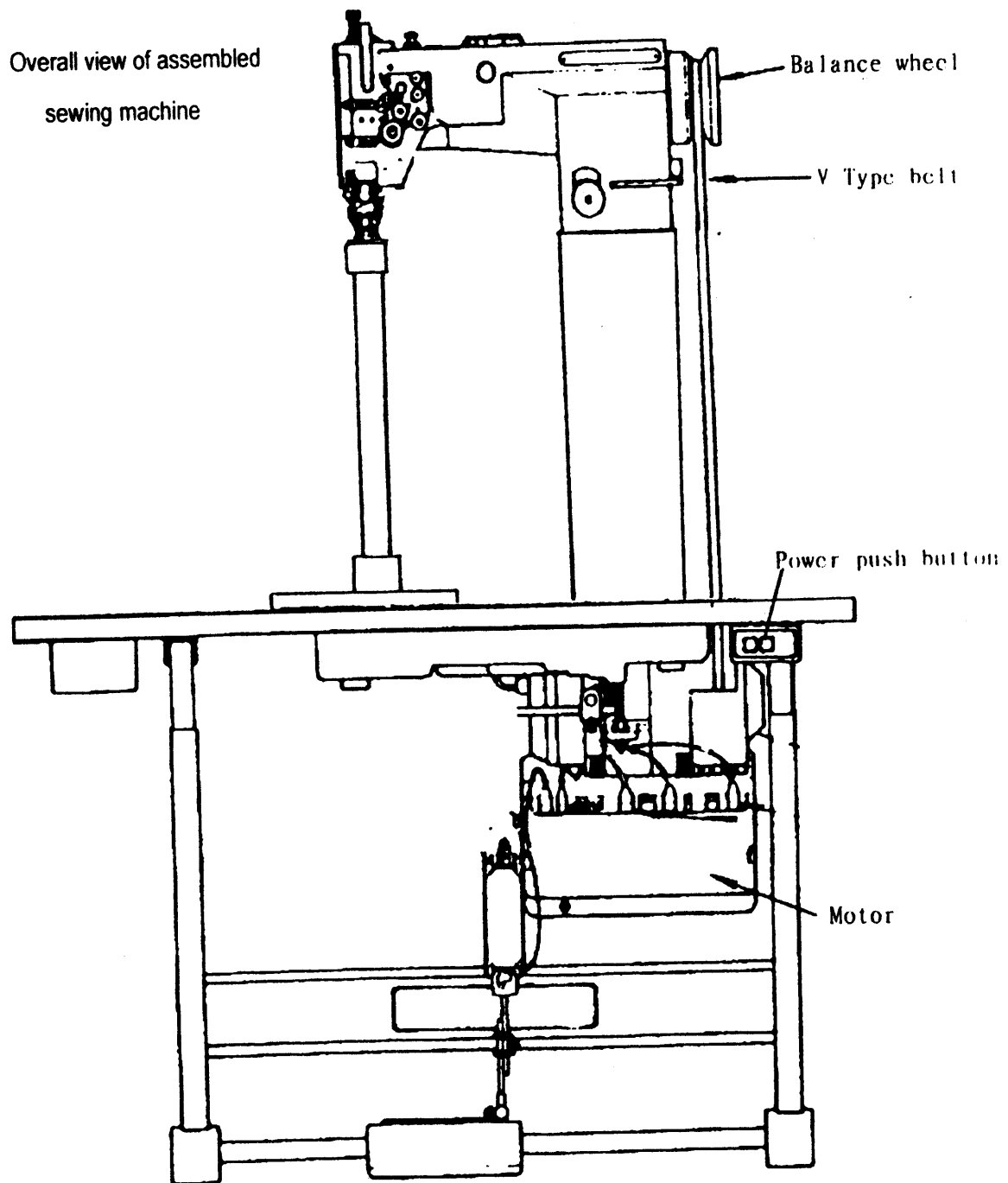

CAUTIONS ON USE

1. Oiling (1)

Filling the oil reservoir with oil up to "H" mark.
Oil level should be periodically checked. If oil level is found below "L" level replenish oil to "H" level.

For oil, Use white spindle oil

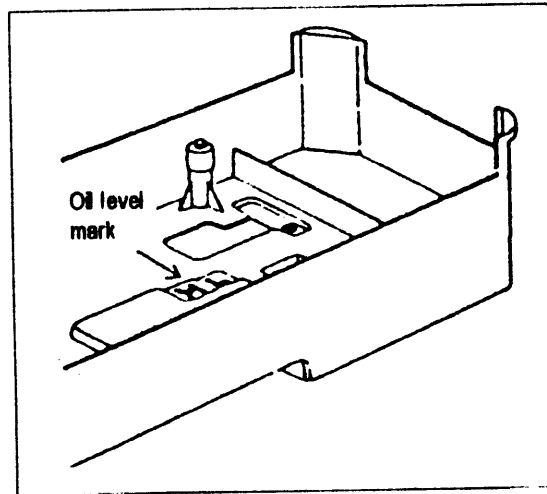

2. Oiling (2)

When a new sewing machine is used for the first time, or sewing machine left out of use for considerably long time is used again, replenish a suitable amount of oil to the portions indicated by arrow in the below figure.

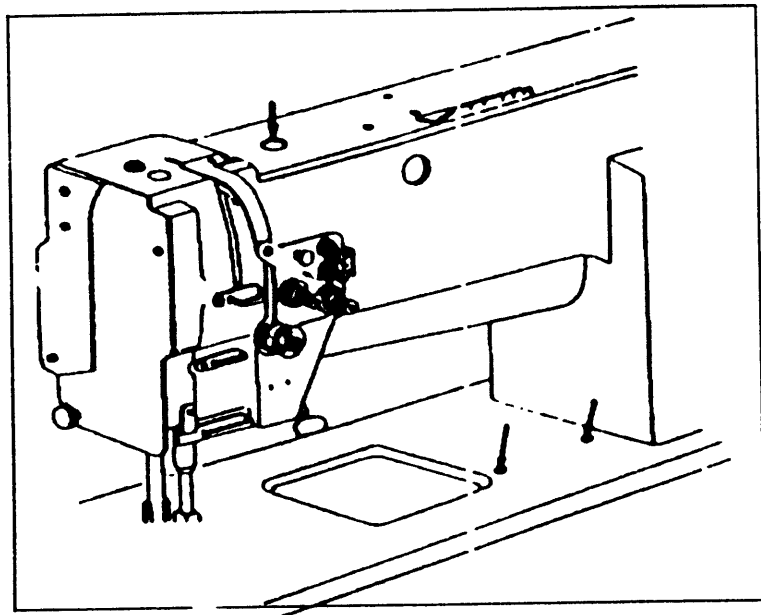
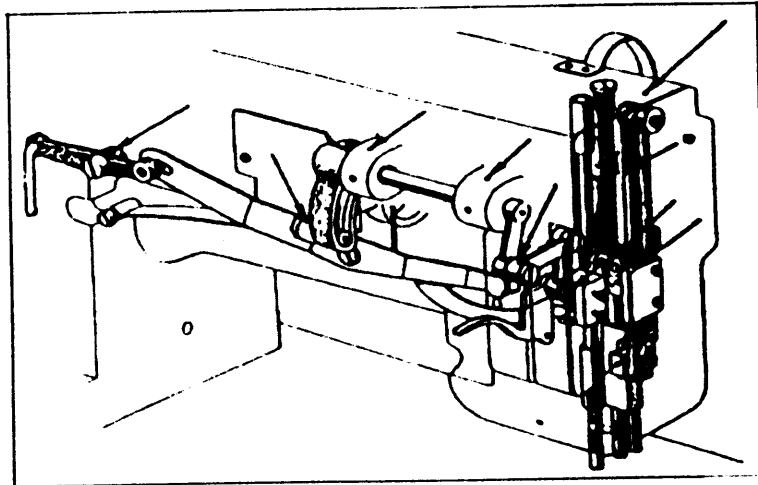

3. Oiling condition

See dripping of oil through the oil sight hole to check oiling condition during operation.

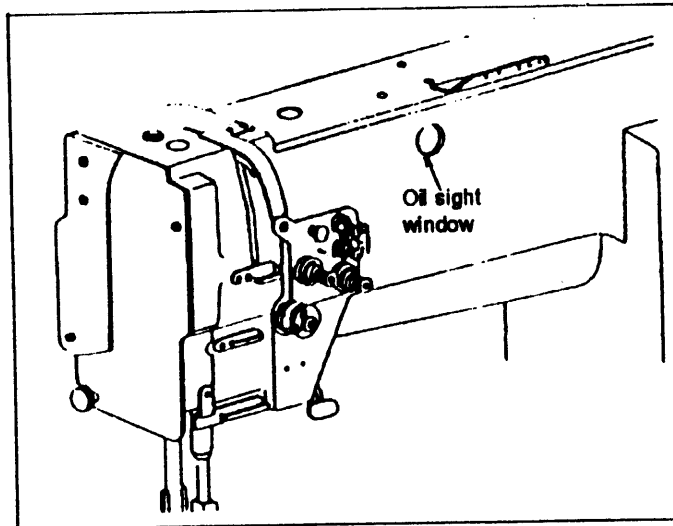

4. Cautions on operation

- (1) When the power is turned on or off, keep foot away from the pedal.
- (2) It should be noted that the brake might not work when the power is interrupted or power failure occurs during sewing machine operation.
- (3) Since dust in the control box might cause malfunction or control troubles, be sure to keep the control box cover close during operation.
- (4) Do not apply a multimeter to the control circuit for checking; otherwise voltage of multimeter might damage semiconductor components in the circuit.

OPERATION

1. Installation of needles

Note: Before installing the needles, be sure to turn off the power.

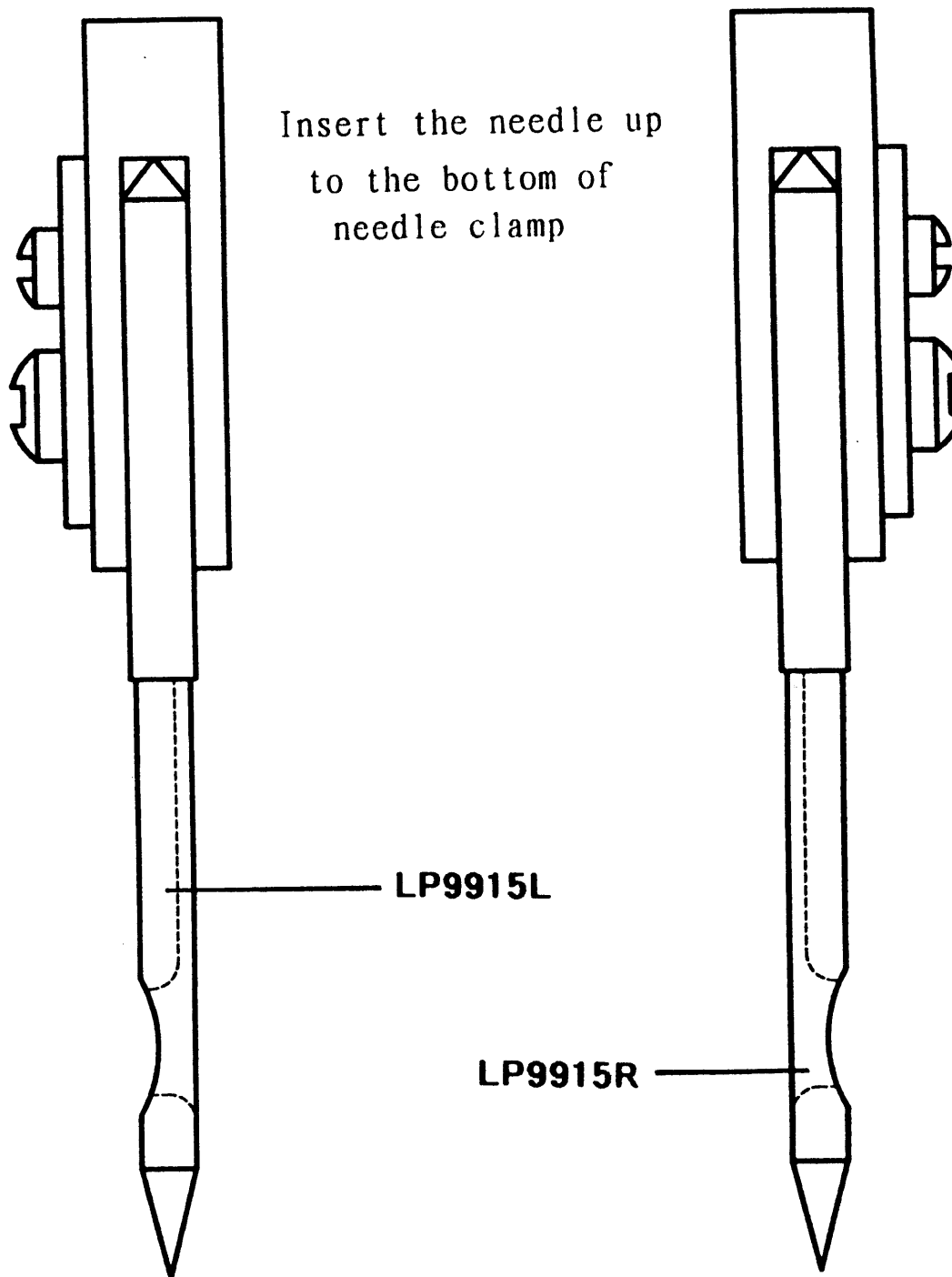

2. Winding of bobbin thread **Note: When bobbin thread is wound, keep the presser foot lifted.**

Adjustment:

- | | |
|-------------------------|---|
| Tension of wound thread | Slack winding is recommended for polyester thread and nylon thread. |
| Conically wound thread | Move the thread guide toward smaller diameter of wound thread layer. |
| Length of wound thread | Loosen the thread length adjusting screw to increase length of thread and tighten the screw to decrease length of thread. |

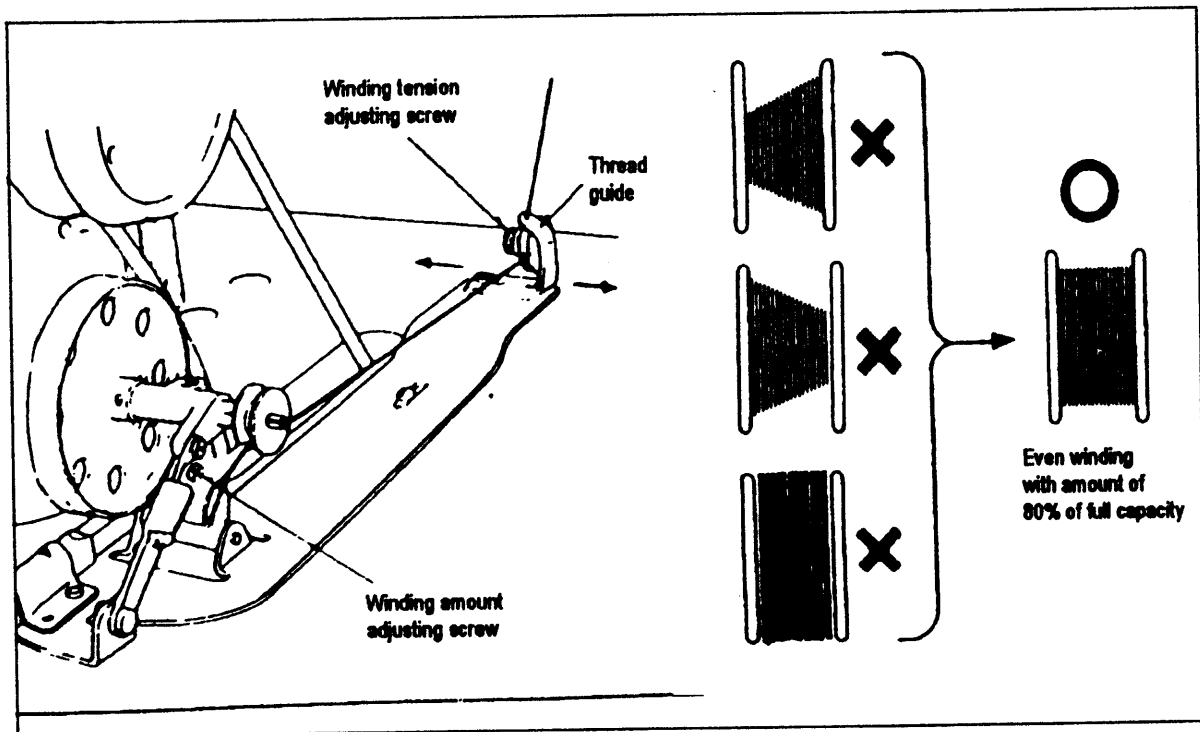

3. Selection of thread

It is recommended to use "S" twist thread in the Left needle (viewed from front), and "Z" twist thread in the right needle.

When discriminate use of needle threads is impossible, use "Z" twist thread in both the needles.

For bobbin thread, "S" twist thread as well as "Z" twist Thread can be used.

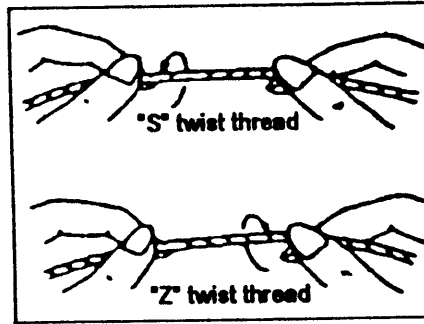

4. Threading of needle threads

(1) Pass each needle thread through thread guide A

Note: When thin slippery thread (polyester Thread or filament thread, for example) is used pass the thread through thread guide B as well.

(2) With the take-up lever located at the upper most position, pass each needle thread in the order shown in the following figure.

Note: Pressing the upper thread loosening button shown in the figure below opens the saucer of the upper thread tension adjuster, and the upper thread can easily pulled out.

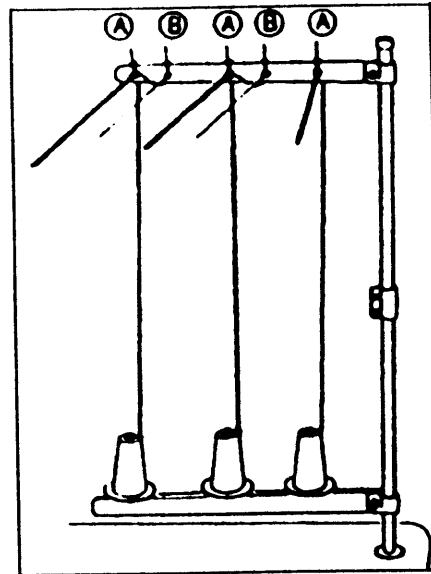

Needle thread tension releasing button

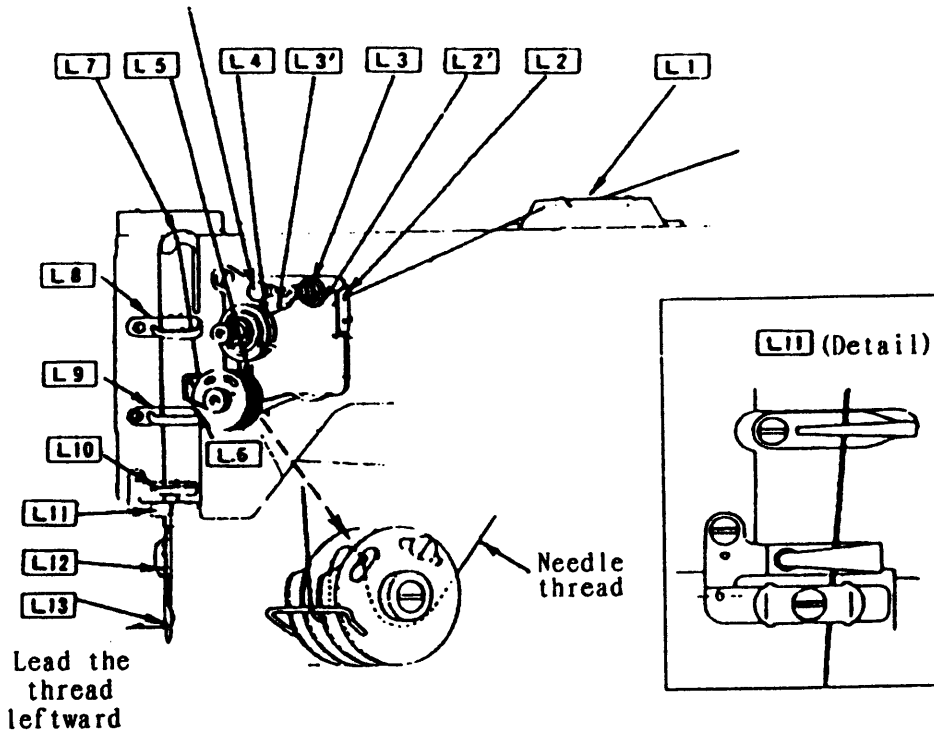

5. Adjustment of feed (stitch) length and stitch reversing (touch back)

Note: To make feed (stitch) length smaller, depress the feed reverse lever and set the feed length setting dial to a desired position.

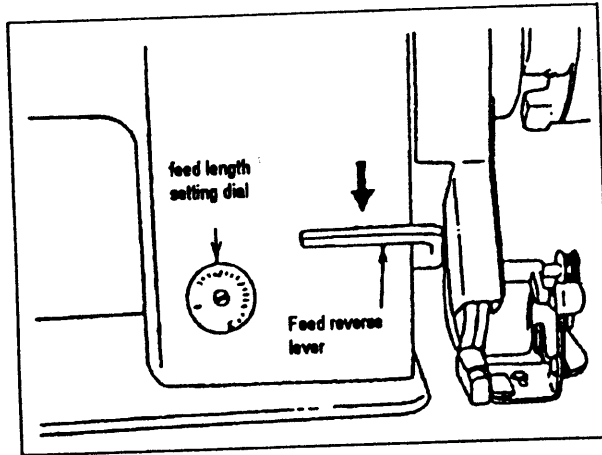

6. Balance of thread tension

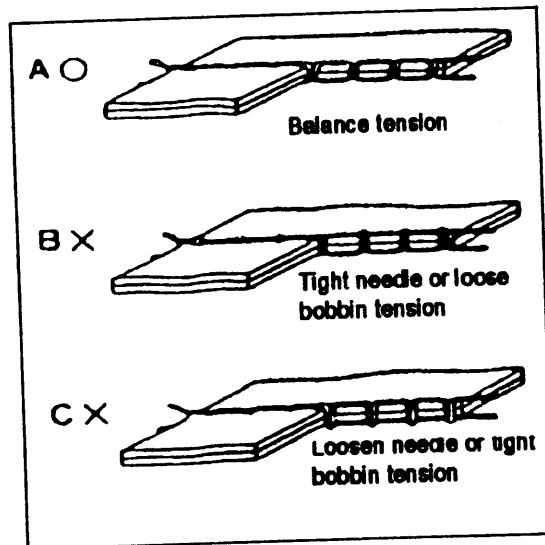

7. Needle thread tension

- Needle thread tension should be adjusted in reference to bobbin thread tension.
- To adjust needle thread tension, turn each tension adjusting nut.

Needle thread tension can be also adjusted for special fabric and thread by changing intensity and movable range of slack thread adjusting spring.

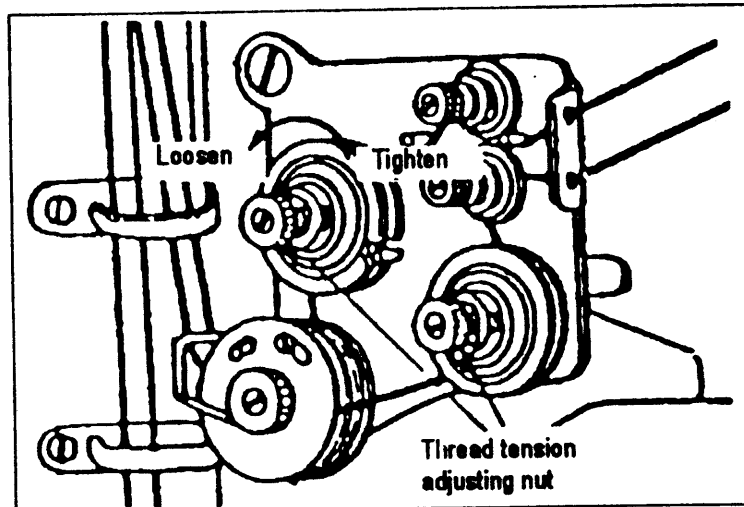

8. Adjustment of presser foot pressure

Pressure to fabric(s) can be adjusted by turning the pressure adjusting screw.

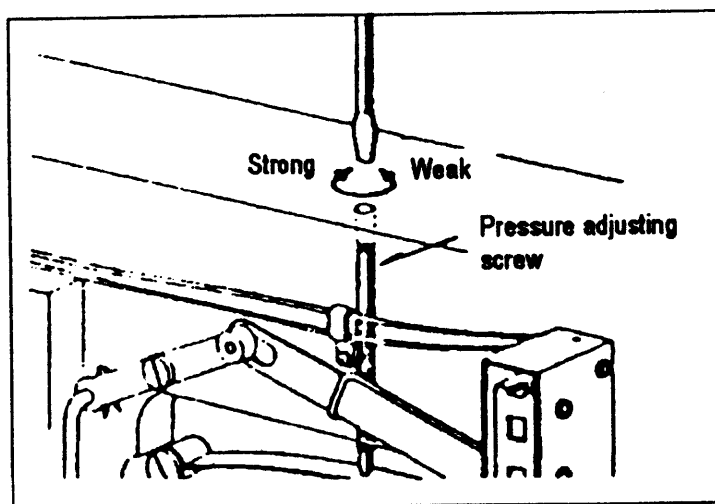

9. Timing between rotating hook motion and needle motion

- (1) Set feed length (stitch length) to "6" on the feed setting dial.
- (2) When needle is lifted 2.4mm from the lower dead point, as shown in Figure, the following positional relationship should be maintained.

The upper edge of needle eye should be 2.3mm below the hook point.

- The hook point should be located at the center of needle axis.
- Gap between the hook point and the side face of needle should be 0.05mm.

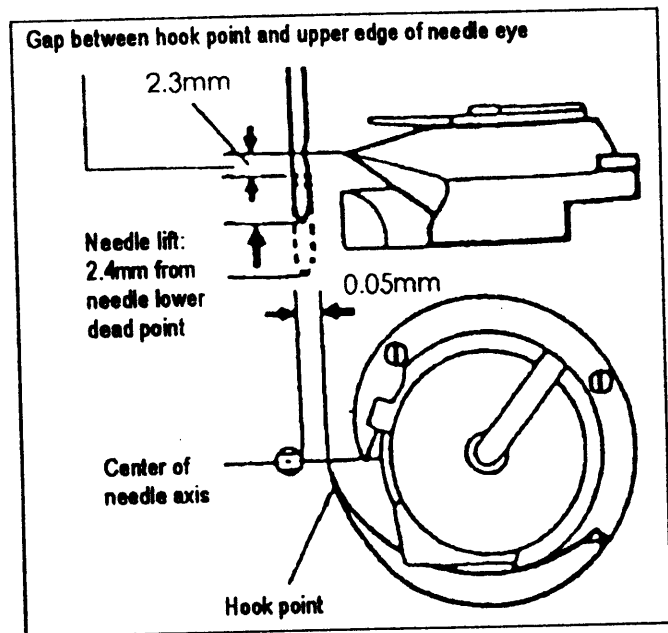

10. Adjustment of feed dog height

Height of feed dog and pressure of presser

Foot should be adjusted for individual fabric(s)

With the following cautions:

- Fabric will be damaged if the feed dog extends too high, or pressure of presser foot is too large.
- Even stitch length cannot be assured if the feed dog is too low or pressure of presser foot is too small.
- Feed dog height should be measured at the point where the needle is at the top position.

For light fabrics	Approx. 0.8mm from Throat plate
For usual fabrics	Approx. 1.0mm from Throat plate
For heavy fabrics	Approx. 1.2mm from Throat plate

Adjustment procedure

- (1) Lean the machine head backward.
- (2) Turn the hand wheel by hand and stop when the feed dog rises to the maximum height.
- (3) Loosen the feed bar set screw.
- (4) Vertically move the feed bar (in the direction indicated by arrow in the figure) to adjust it to adequate height.
- (5) After the adjustment, tighten the feed bar set screw.

The feed dog height is factory-adjusted to 1.2mm

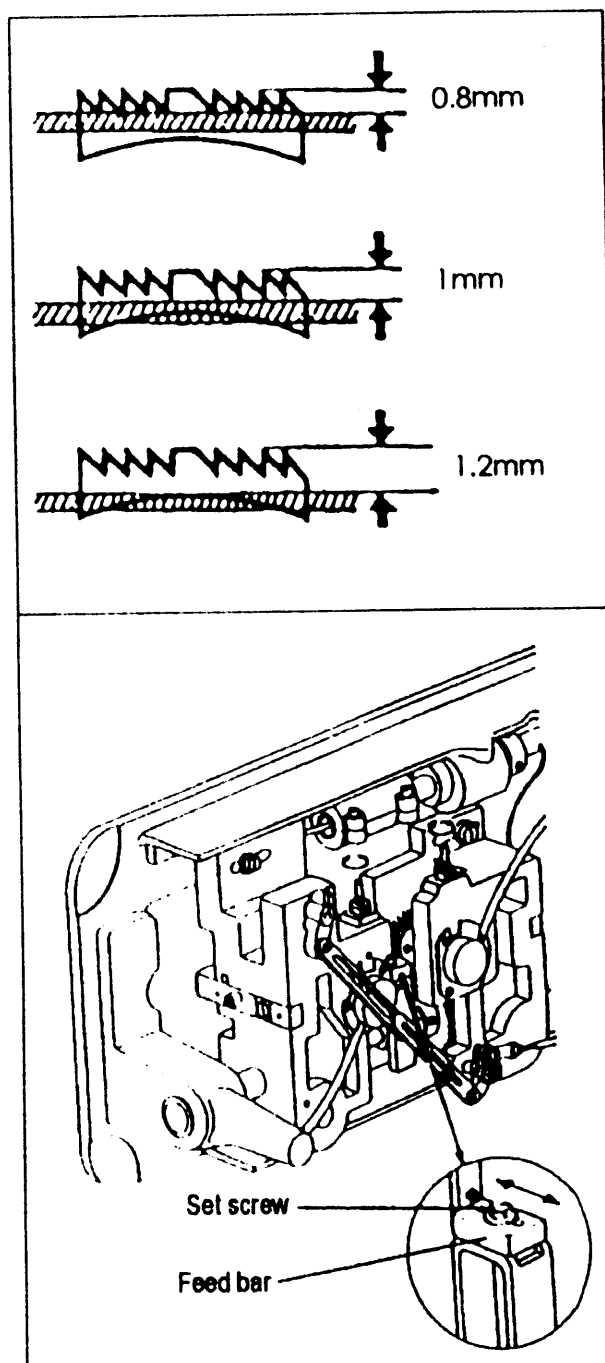

11. Relationship between rotating hook motion and take-up lever motion

when the timing belt (toothed belt) was removed for its replacement, for example, the relationship between rotating hook motion and take-up lever motion should be adjusted as follows:

- (1) Turn the balance wheel and stop when the take-up lever is lifted to its upper dead point.
- (2) Lean the machine head backward and make sure the arrow (timing mark) put on the timing belt is in line with the black line on the boss of lower shaft bearing.
- (3) If the timing mark is not in line with the black line, remove the timing belt and install it again to adjust

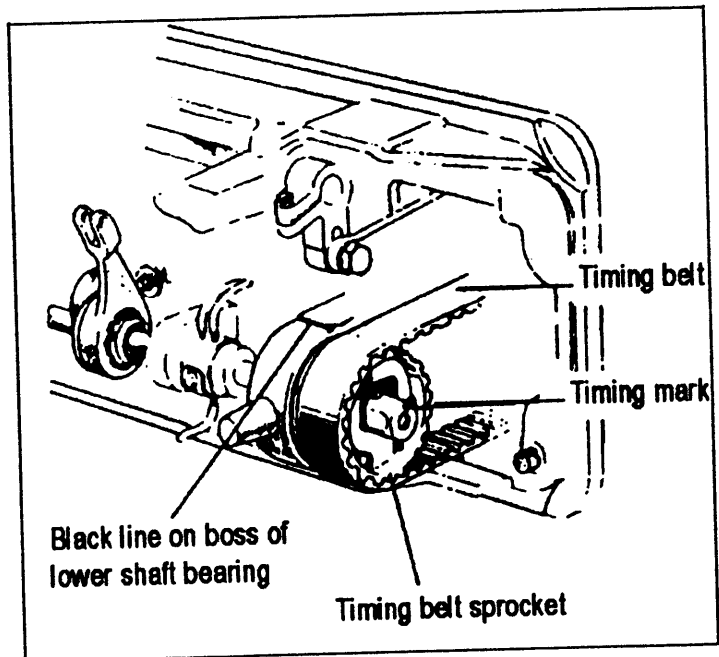

12. Relationship between needle motion and feed dog motion

- (1) Set feed length to "0" on the feed setting dial
- (2) Lean the machine head backward.
- (3) Loosen the feed lifting rock shaft crank set Screws A and B
- (4) Set the needle at the lowest position.
- (5) Adjust the distance between presser rod and Vibration prevention rod to 9mm and temporarily tighten the feed lifting rock shaft crank set screws A and B
- (6) Check that the right feed lifting rock shaft crank is connected with the link at right angle, as shown in Figure.
- (7) If the connection is not at right angle, remove the back cover, loosen screw C and move the right link to connect the right feed lifting rock shaft with the link at right angle.
- (8) After the completion of adjustment, fully tighten The screws A, B and C.

At this time make certain that needle can enter the feed dog needle hole at the center of the hole.

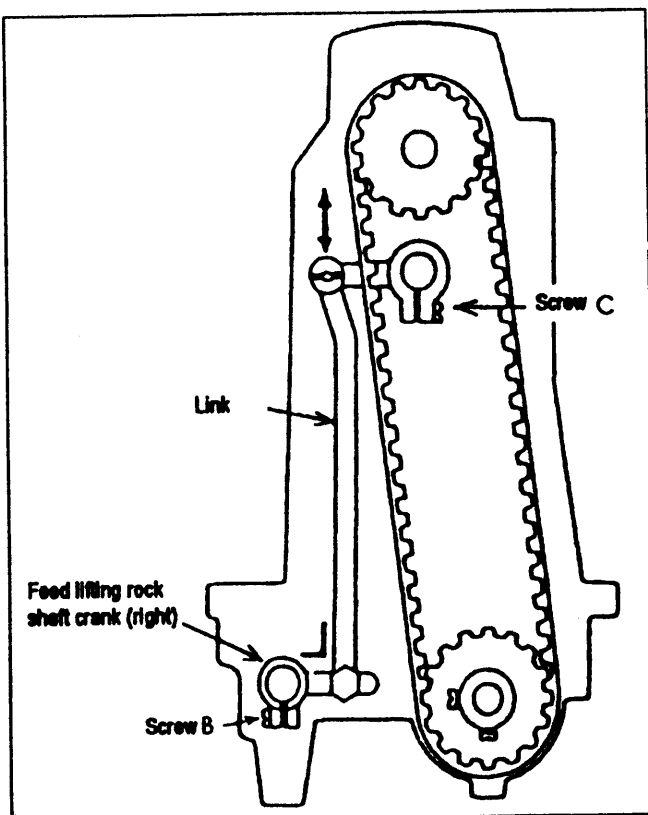
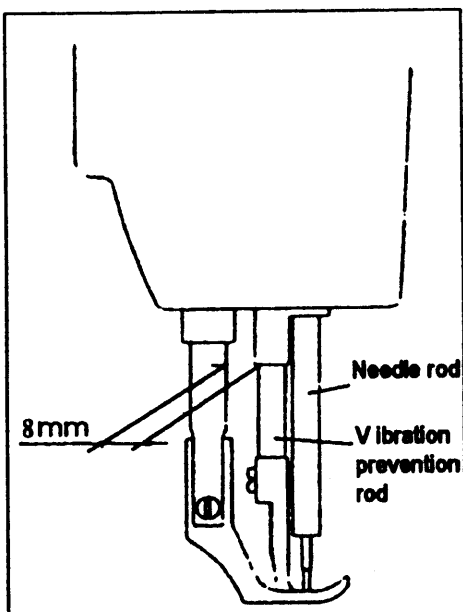
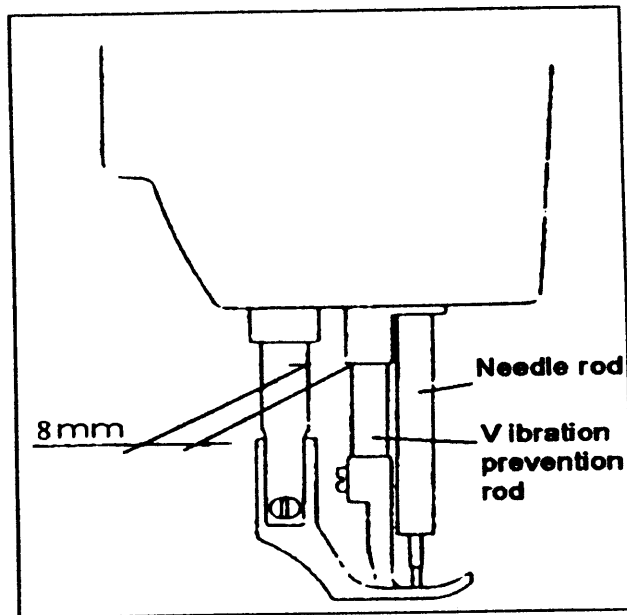

13. SAFETY CLUTCH DEVICE:

Safety clutch device is installed to prevent the hook and cog belt from damage in case the thread is caught into the hook when the machine is loaded abnormally during operation.

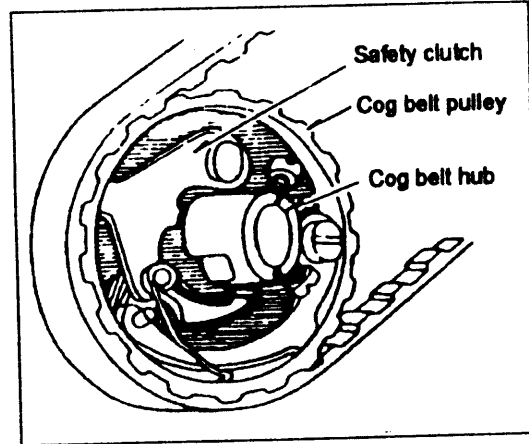

(1) FUNCTION OF SAFETY CLUTCH.

- A. When the safety clutch acts, the cog belt pulley will be unloaded. Then the rotation of hook shaft will stop. The arm shaft only will rotate. Stop the operation of machine.
- B. Clean the thread thoroughly which is caught into the hook.
- C. Turn the cog belt hub by hand, and check whether the hook shaft rotates lightly and properly, place the clutch device as follows.

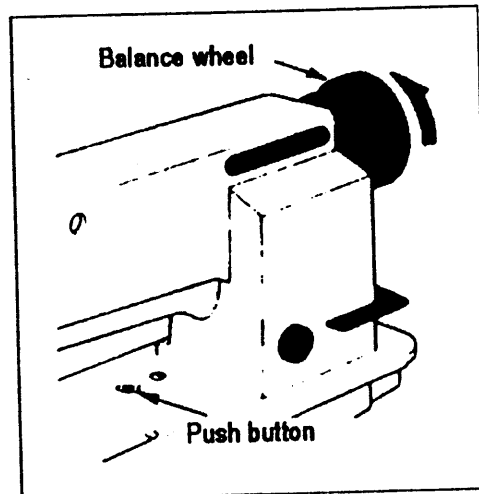

(2) HOW TO SET THE SAFETY CLUTCH.

- A. While pressing down the push button on the opposite side of bed by left hand, turn the balance wheel slowly by right hand away from you as shown in the figure.
- B. The balance wheel will stop by the gear plate, but turn the balance wheel more firmly.
- C. Release the push button.
- D. As shown in the Figure, the safety clutch device is set.

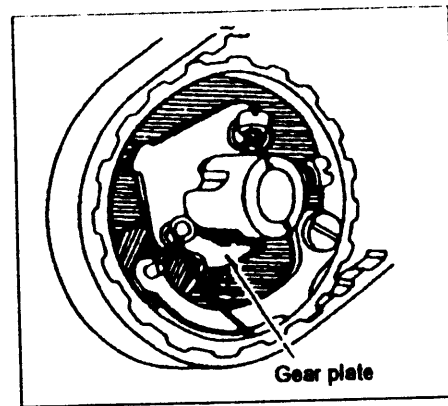

(3) FORCE APPLIED TO THE SAFETY CLUTCH.

- A. The force applied to the safety clutch is the smallest when the white mark of the eccentric pin faces the center of the lower shaft. The force proportionally increases as the white mark faces the outside.
- B. To adjust the force slide the timing belt, Loosen the set screw, and turn the eccentric pin.
- C. After the adjustment, make sure to fasten the set screw.

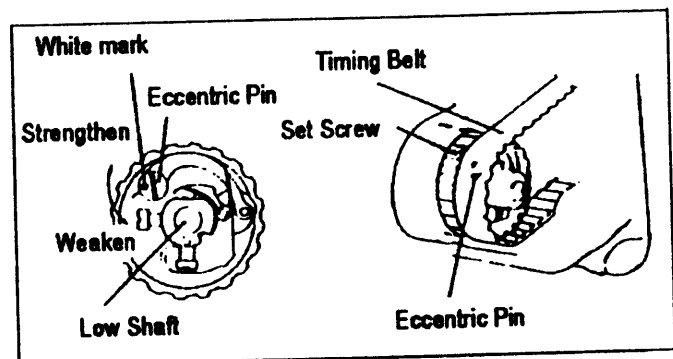

14. UPPER FEED ADJUSTMENT (NEEDLE SIDE)

If the uneven feeding occurs according to the fabric, adjust the long hole of the horizontal feed shaft crank (right) to adjust the upper feed length.

(How to adjust)

- (1) Loosen the special bolt.
- (2) Move the special bolt upward to decrease upper feed.
- (3) Move the special bolt downward to increase the upper feed. The upper feed and the lower feed theoretically becomes equal at the reference line on the horizontal feed shaft crank.
- (4) Securely tighten the special bolt after adjustment.

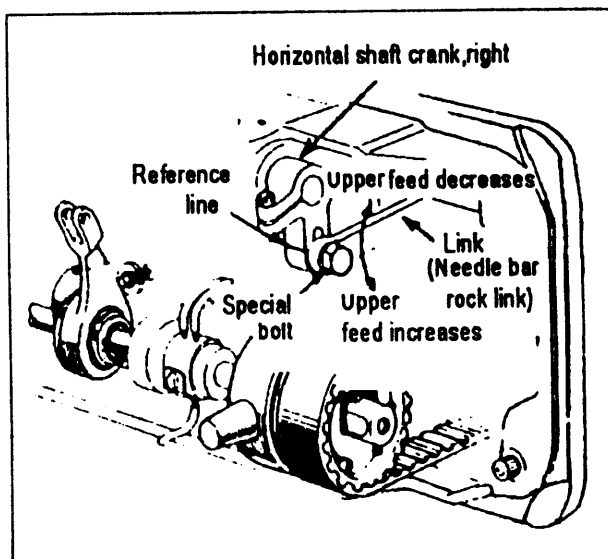

15. Outside presser foot and inside presser vertical stroke adjustment

When fabric with large elasticity is sewn,
Or When thickness of fabric changes, the vertical Stroke (movable range) of the press feet should be adjusted as follows:

Adjustment

- (1) Loosen the special bolt.
- (2) The vertical strokes of the presser feet become maximum when the crank rod is moved upward and set.
- (3) The vertical strokes becomes minimum when the nut is moved downward and set.
- (4) After the adjustment, fully tighten the special bolt.

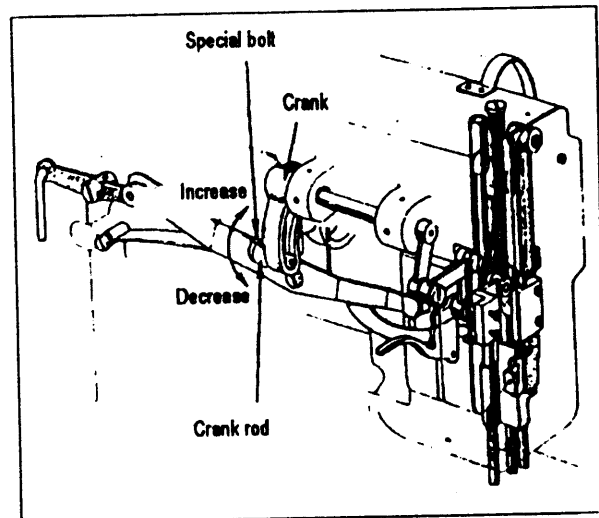

The vertical strokes of the presser feet can be adjusted within a range from 6mm to 2mm.

16. Adjustment

Screwing the pin that connects the link of back-sewing with the crank of back-sewing (down) can adjust the tolerance of between the stitches. Screwing the pin in clockwise can increase the stitch of forward sewing; otherwise, the stitch of back-sewing will be increased.

Model Specitication	LP9915L	LP9915R
Position of post-bed	Left	Right
Application	Heavy material	
Max.sewing speed	1600rpm	
Stitch length	0-6mm	
Thread take-up lever stroke	74.5mm	
Needle-bar stroke	36mm	
Presser-foot stroke	15 by foot	8 by hand
Vertical stroke of upper feed	2-6mm	
Needle No.	DP×17 (#23 standard)	
Thread take-up lever	Slide lever	
Stitch adjusting system	Dial	
Lubrication system	Automatic lubrication	
Motor	Clutch motor	

A: BODY AND IT'S ACCESSORIES

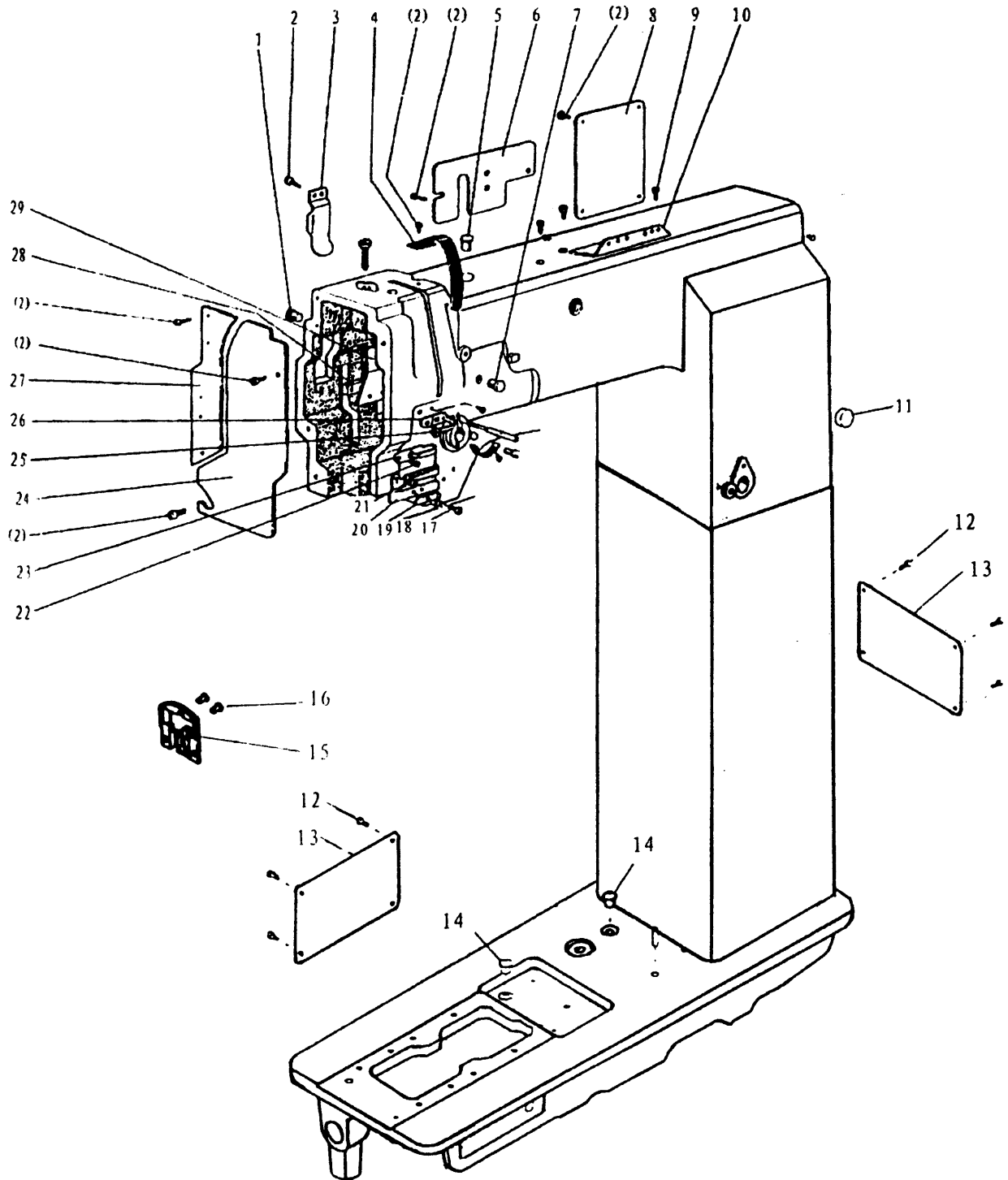

A:BODY AND IT'S ACCESSORIES

No.	Ref.No.	Description	Pcs.
1	H71A001	Rubber plug	2
2	H71A002	Screw	22
3	H71A003	Oil guard plate	1
4	H71A004	Thread take-up cover	1
5	H71A005	Rubber plug	1
6	H71A006	Side cover(left)	1
7	H71A007	Rubber plug	1
8	H71A008	Side cover(right)	1
9	H71A009	Screw	2
10	H71A010	Thread guide	1
11	H71A011	Rubber plug	1
12	H71A012	Screw	8
13	H71A013	Cover	1
14	H71A014	Cap	2
15	H71A015	Needle plate	1
16	H71A016	Screw	2
17	H71A017	Thread guide(complete)	1
18	H71A018	Spring	1
19	H71A019	Plate	1
20	H71A020	Thread guide	1
21	H71A021	Screw	1
22	H71A022	Screw	1
23	H71A023	Thread guide(middle)	1
24	H71A024	Face plate	1
25	H71A025	Screw	2
26	H71A026	Thread guide(upper)	1
27	H71A027	Guide mounting plate	1
28	H71A028	Plate for oil guide	1
29	H71A029	Oil guard	1

B: THREAD TENSION REGULATOR MECHANISM

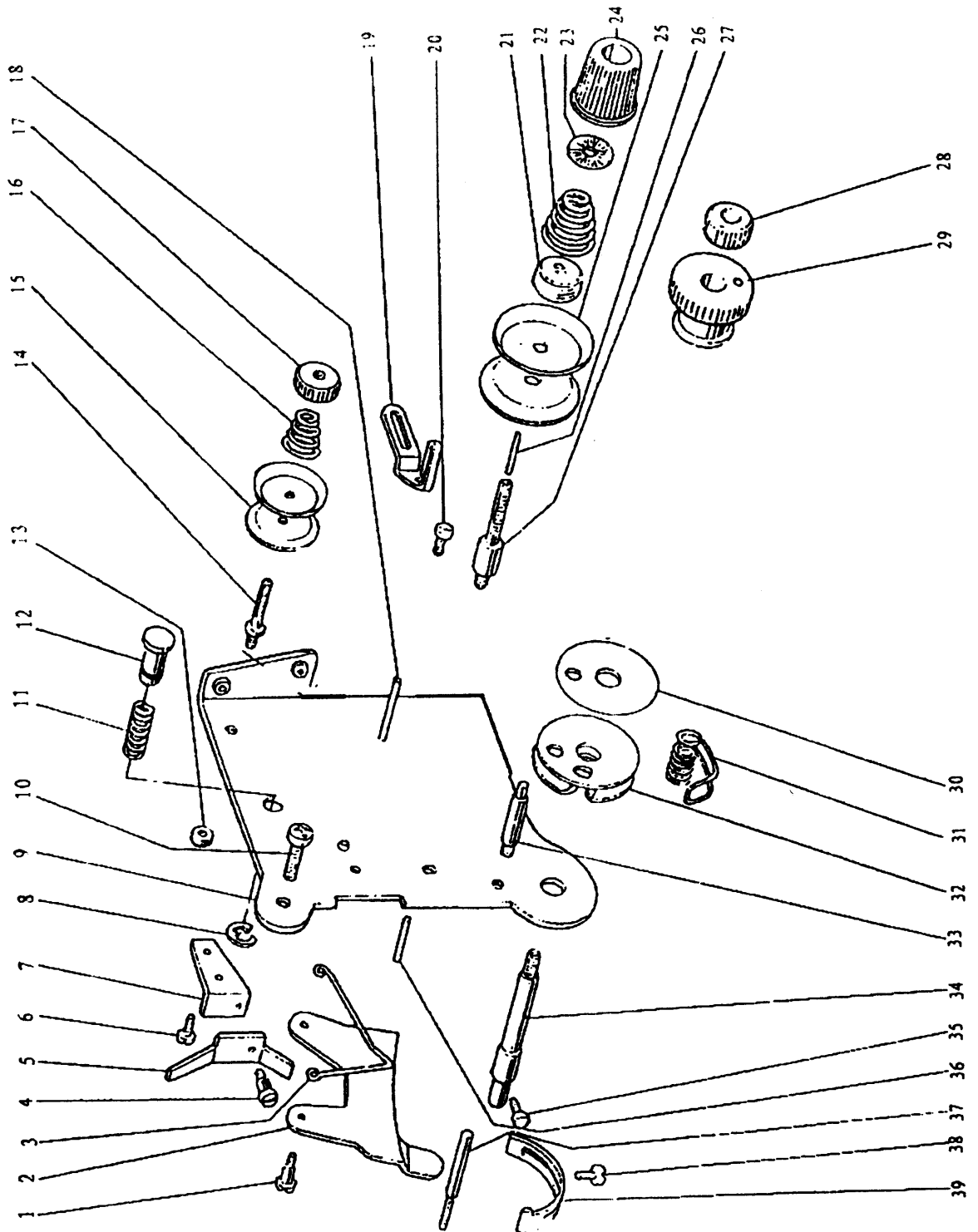

B:THREAD TENSION REGULATOR MECHANISM

No.	Ref.No.	Description	Pcs.
1	H71B001	Screw	2
2	H71B002	Tension releasing plate	1
3	H71B003	Tension releasing spring	1
4	H71B004	Screw	1
5	H71B005	Lever	1
6	H71B006	Screw	1
7	H71B007	Mounting plate	1
8	H71B008	Stop ring	1
9	H71B009	Mounting plate	1
10	H71B010	Screw	2
11	H71B011	Spring	1
12	H71B012	Push button	1
13	H71B013	Nut	2
14	H71B014	Screw	1
15	H71B015	Thread tension disk	2
16	H71B016	Spring	1
17	H71B017	Nut	1
18	H71B018	Pin	1
19	H71B019	Thread guide	1
20	H71B020	Screw	1
21	H71B021	Thread tension disk	1
22	H71B022	Spring	1
23	H71B023	Thumb nut revolution stopper	1
24	H71B024	Thumb nut complete	1
25	H71B025	Thread tension disk	2
26	H71B026	Pin	1
27	H71B027	Screw	1
28	H71B028	Nut	1
29	H71B029	Take-up spring guide	1
30	H71B030	Plate	1
31	H71B031	Spring	1
32	H71B032	Plate complete	1
33	H71B033	Screw	1
34	H71B034	Screw	1
35	H71B035	Screw	1
36	H71B036	Pin	1

B:THREAD TENSION REGULATOR MECHANISM

No.	Ref.No.	Description	Pcs.
37	H71B037	Pin	1
38	H71B038	Screw	1
39	H71B039	Stopper	1

C: UPPER SHAFT MECHANISM

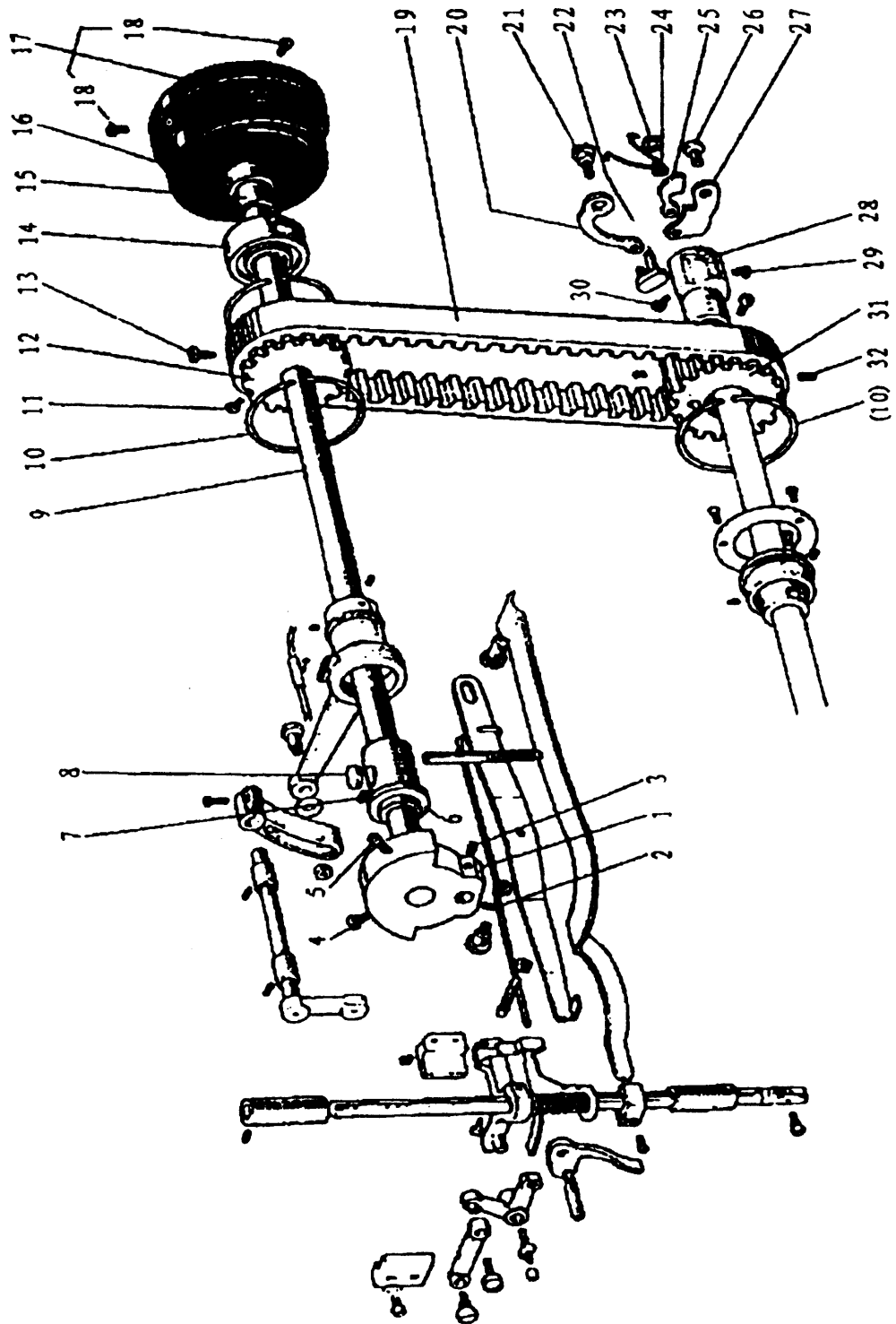

C:UPPER SHAFT MECHANISM

No.	Ref.No.	Description	Pcs.
1	H71C001	Needle bar crank complete	1
2	H71C002	Screw	1
3	H71C003	Screw	1
4	H71C004	Screw	1
5	H71C005	Screw	1
6	H71C006	Arm shaft bushing(left)	1
7	H71C007	Screw	1
8	H71C008	Felt	1
9	H71C009	Arm shaft	1
10	H71C010	Spring flange	3
11	H71C011	Screw	1
12	H71C012	Belt pulley(upper)	1
13	H71C013	Screw	1
14	H71C014	Bearing	1
15	H71C015	Ring	1
16	H71C016	Screw	2
17	H71C017	Pulley	1
18	H71C018	Screw	2
19	H71C019	Cog belt	1
20	H71C020	Link	1
21	H71C021	Pin	1
22	H71C022	Pin	1
23	H71C023	E-type stop ring	1
24	H71C024	Spring	1
25	H71C025	Link	1
26	H71C026	Pin	1
27	H71C027	Link	1
28	H71C028	Shaft	1
29	H71C029	Screw	1
30	H71C030	Screw	1
31	H71C031	Belt pulley(lower)	1
32	H71C032	Screw	2

D: PRESSER FOOT MECHANISM

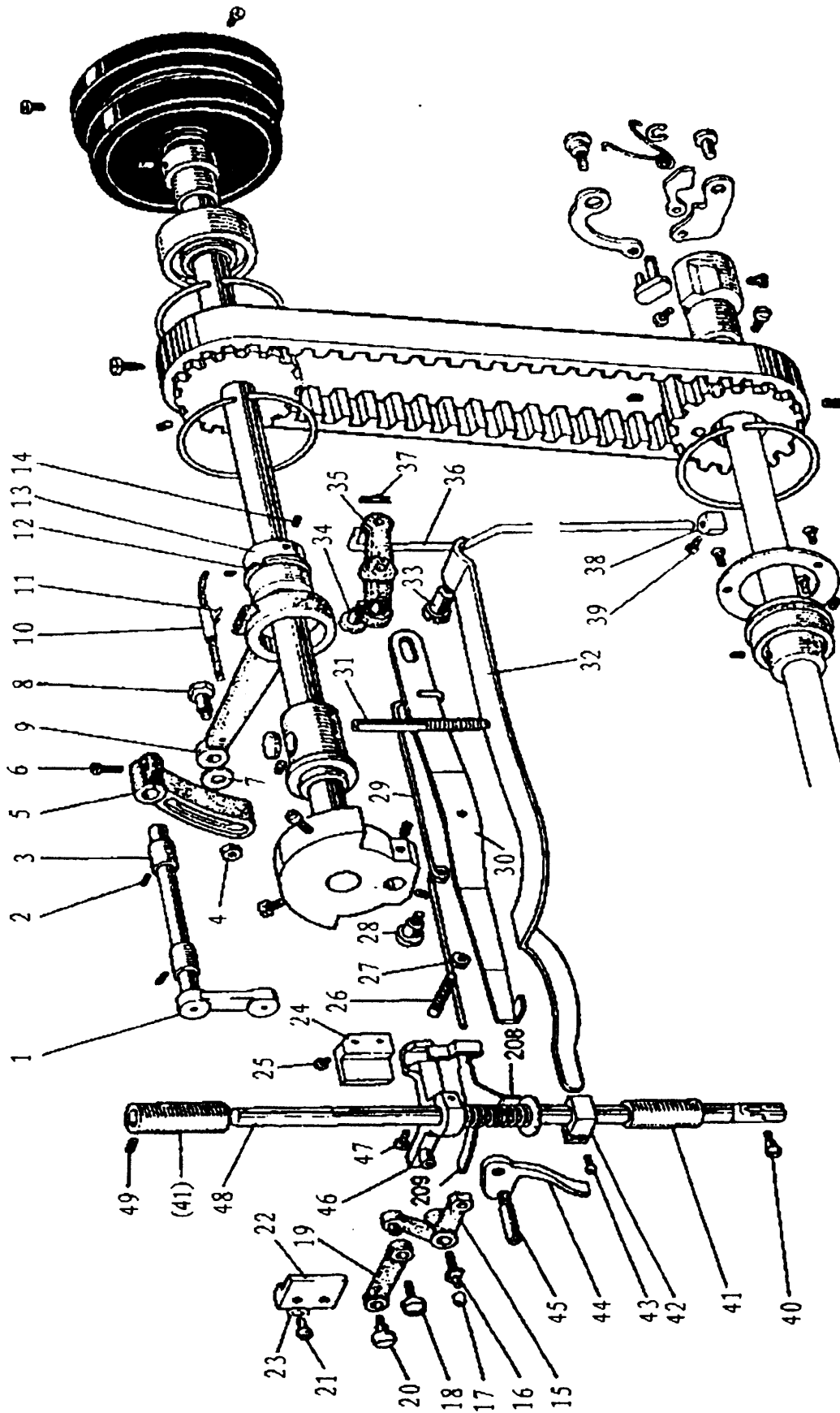

D:PRESSER FOOT MECHANISM

No.	Ref.No.	Description	Pcs.
1	H71D001	Feed lifting rock shaft	1
2	H71D002	Screw	2
3	H71D003	Bushing	2
4	H71D004	Nut	1
5	H71D005	Lever	1
6	H71D006	Screw	1
7	H71D007	Washer	1
8	H71D008	Bolt	1
9	H71D009	Connecting rod	1
10	H71D010	Oil pipe \$ wick complete	1
11	H71D011	Spring	1
12	H71D012	C-type stop ring	1
13	H71D013	Eccentric	1
14	H71D014	Screw	2
15	H71D015	Bell crank	1
16	H71D016	Support shaft	1
17	H71D017	Roller	1
18	H71D018	Screw	1
19	H71D019	Link	1
20	H71D020	Screw	1
21	H71D021	Screw	2
22	H71D022	Guide	1
23	H71D023	Washer	2
24	H71D024	Guide	1
25	H71D025	Screw	2
26	H71D026	Screw	1
27	H71D027	Nut	1
28	H71D028	Screw	1
29	H71D029	Spring	1
30	H71D030	Lever	1
31	H71D031	Screw	1
32	H71D032	Spring	1
33	H71D033	Screw	1
34	H71D034	Screw	1
35	H71D035	Knee lifter lifting lever complete	1
36	H71D036	Link	1

D:PRESSER FOOT MECHANISM

No.	Ref.No.	Description	Pcs.
37	H71D037	Snap pin	1
38	H71D038	Collar	1
39	H71D039	Screw	1
40	H71D040	Screw	1
41	H71D041	Bushing	2
42	H71D042	Spring bracket	1
43	H71D043	Screw	1
44	H71D044	Lifter lever	1
45	H71D045	Screw	1
46	H71D046	Bracket	1
47	H71D047	Screw	1
48	H71D048	Presser bar	1
49	H71D049	Screw	2

E: NEEDLE BAR AND THREAD TAKE-UP LEVER MECHANISM

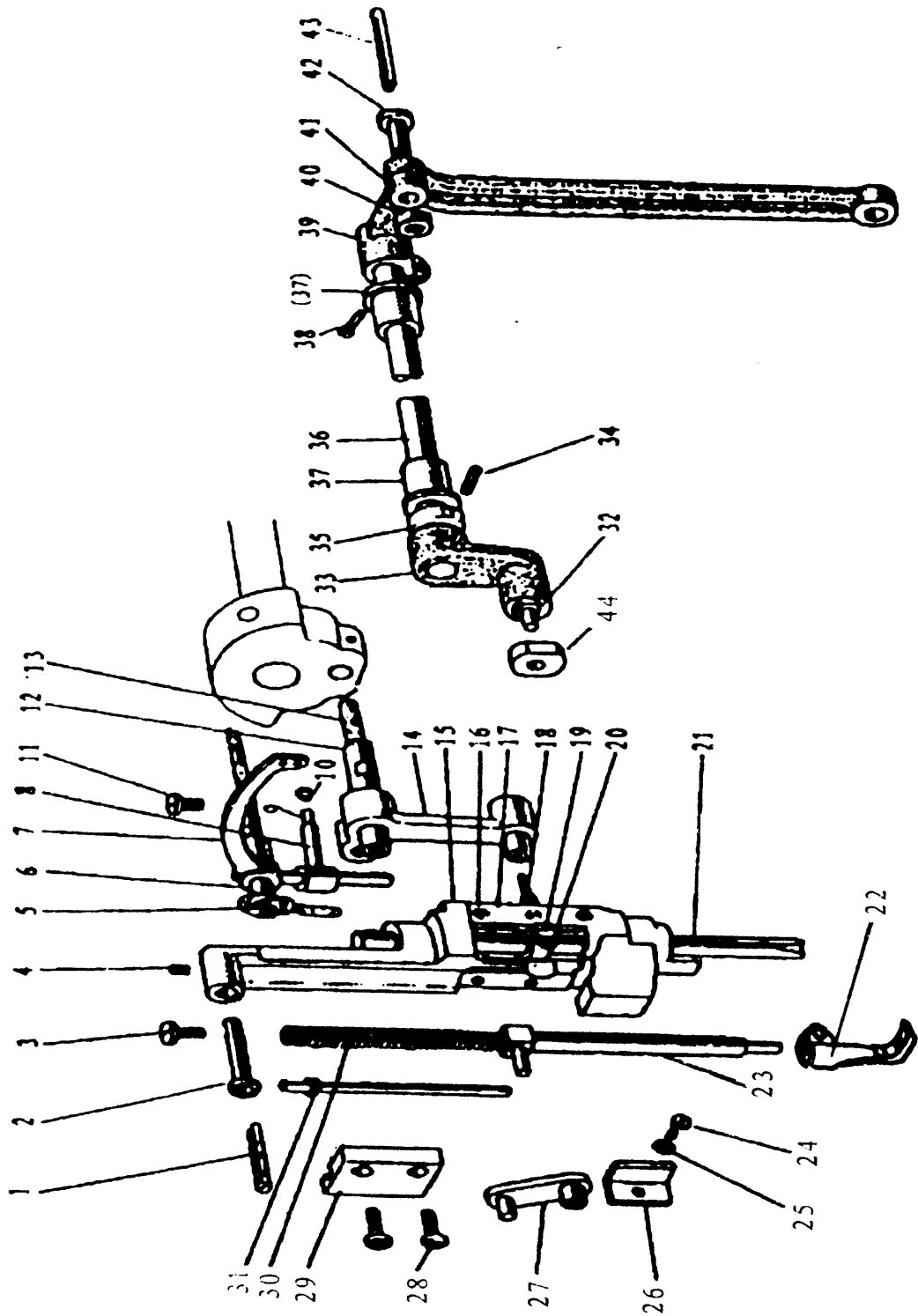

E: NEEDLE BAR AND THREAD TAKE-UP LEVER MECHANIS

M

No.	Ref.No.	Description	Pcs.
1	H71E001	Oil wick	1
2	H71E002	Needle bar guide bracket stud	1
3	H71E003	Screw	1
4	H71E004	Screw	1
5	H71E005	Oil wick	1
6	H71E006	Thread take-up lever support stud	1
7	H71E007	Thread take-up lever	1
8	H71E008	Slide bar	1
9	H71E009	Oil wick	1
10	H71E010	Plup	1
11	H71E011	Screw	1
12	H71E012	Needle bar crank pin	1
13	H71E013	Oil wick	1
14	H71E014	Connecting link	1
15	H71E015	Needle bar guide bracket	1
16	H71E016	Screw	6
17	H71E017	Spacer	2
18	H71E018	Felt	1
19	H71E019	Needle bar holder	1
20	H71E020	Screw	1
21	H71E021	Needle bar	1
22	H71E022	Inside presser foot	1
23	H71E023	Presser bar	1
24	H71E024	Screw	1
25	H71E025	Washer	1
26	H71E026	Needle bar guide	1
27	H71E027	Lever	1
28	H71E028	Screw	2
29	H71E029	Guide	1
30	H71E030	Spring	1
31	H71E031	Vibrating presser spring guide	1
32	H71E032	Screw	1
33	H71E033	Needle bar vibrating crank(left)	1
34	H71E034	Taper	1
35	H71E035	Collar	1
36	H71E036	Needle bar vibrating shaft	1

E:NEEDLE BAR AND THREAD TAKE-UP LEVER MECHANIS

M

No.	Ref.No.	Description	Pcs.
37	H71E037	Bushing	2
38	H71E038	Screw	1
39	H71E039	Needle bar vibrating crank(right)	1
40	H71E040	Nut	1
41	H71E041	Link	1
42	H71E042	Screw	1
43	H71E043	Oil wick	1
44	H71E044	Square block	1

F: STITCH REGULATOR MECHANISM

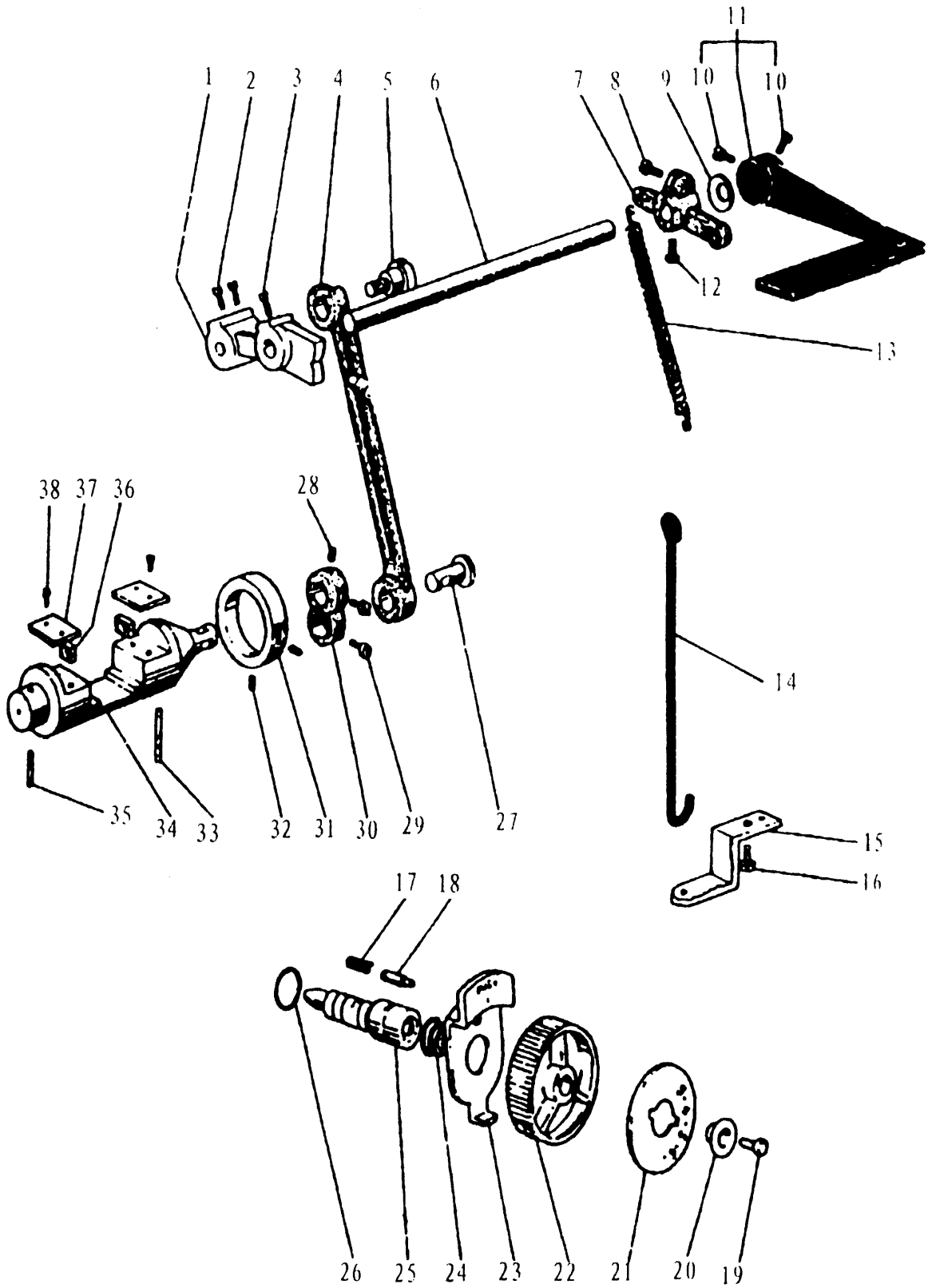

F:STITCH REGULATOR MECHANISM

No.	Ref.No.	Description	Pcs.
1	H71F001	Feed regulator cam	1
2	H71F002	Screw	2
3	H71F003	Screw	1
4	H71F004	Link	1
5	H71F005	Eccentric shaft	1
6	H71F006	Reverse stitch shaft(upper)	1
7	H71F007	Crank	1
8	H71F008	Screw	1
9	H71F009	Washer	1
10	H71F010	Screw	2
11	H71F011	Lever	1
12	H71F012	Screw	1
13	H71F013	Spring	1
14	H71F014	Link	1
15	H71F015	spring bracket	1
16	H71F016	Screw	1
17	H71F017	Spring	1
18	H71F018	Pin	1
19	H71F019	Screw	1
20	H71F020	Bushing	1
21	H71F021	Stitch length indicating plate	1
22	H71F022	Dial	1
23	H71F023	Stopper pin releasing lever	1
24	H71F024	Coil spring	1
25	H71F025	Screw bar	1
26	H71F026	O-ring	1
27	H71F027	Pin	1
28	H71F028	Screw	1
29	H71F029	Screw	2
30	H71F030	Reverse sewing crank	1
31	H71F031	Collar	1
32	H71F032	Screw	2
33	H71F033	Felt	1
34	H71F034	Reverse block	1
35	H71F035	Felt	1
36	H71F036	Square block	2

F:STITCH REGULATOR MECHANISM

No.	Ref.No.	Description	Pcs.
37	H71F037	Guide plate	2
38	H71F038	Screw	4

G: LOWER SHAFT AND FEED ROCKING MOTION MECHANISM

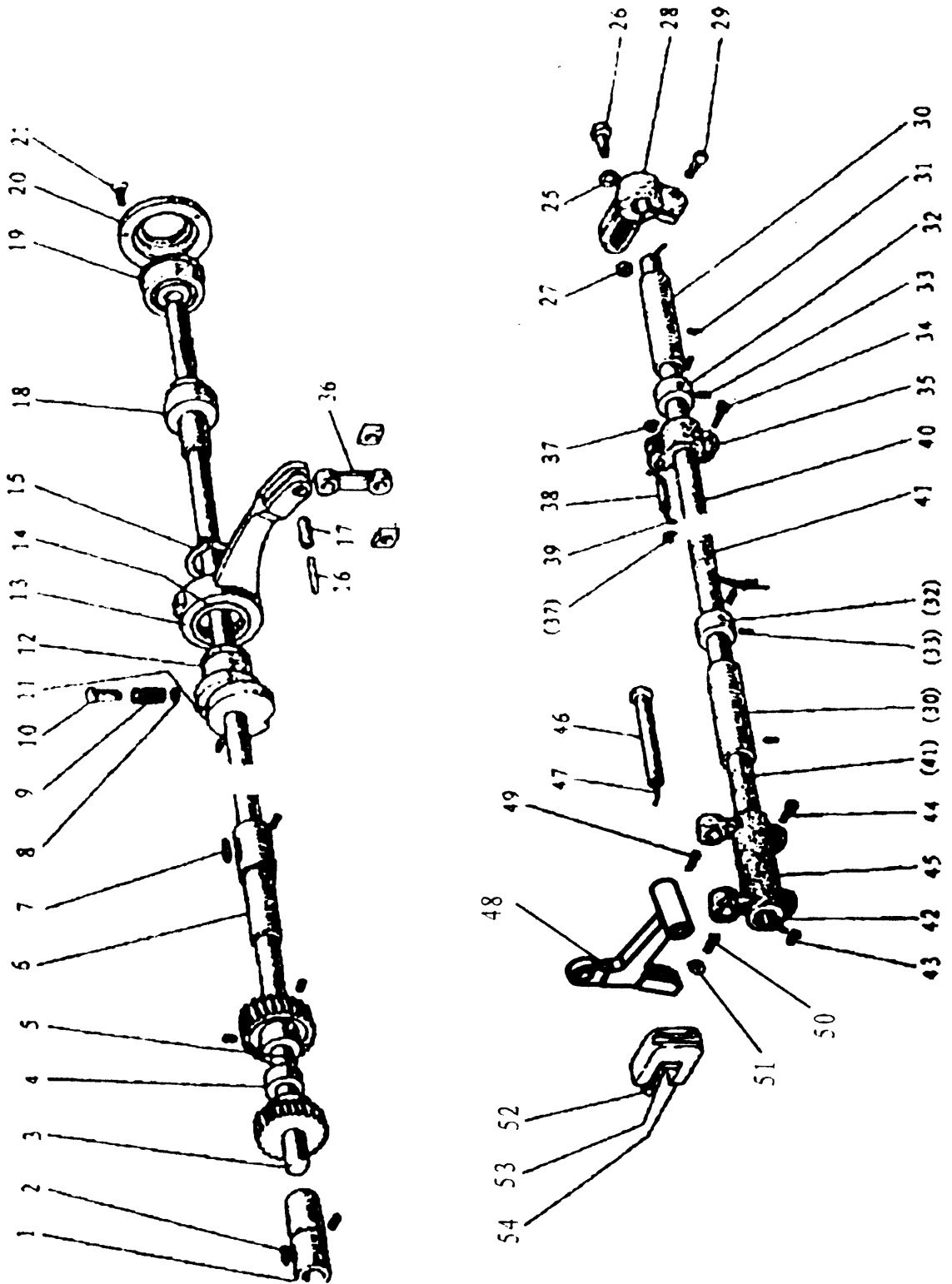

G:LOW SHAFT AND FEED ROCKING MOTION MECHANISM

No.	Ref.No.	Description	Pcs.
1	H71G001	Lower shaft bushing(left)	
2	H71G002	Oil wick	1
3	H71G003	Lower shaft	1
4	H71G004	Feed eccentric cam	1
5	H71G005	Screw	1
6	H71G006	Lower shaft bushing(right)	1
7	H71G007	Oil wick	1
8	H71G008	Stop ring	2
9	H71G009	Spring	1
10	H71G010	Push button	1
11	H71G011	Screw	2
12	H71G012	Feed eccentric	1
13	H71G013	Feed connecting rod	1
14	H71G014	Needle bearing	1
15	H71G015	C-type stop ring	1
16	H71G016	Oil wick	1
17	H71G017	shaft	1
18	H71G018	Lower shaft bushing complete(mid)	1
19	H71G019	Bushing	1
20	H71G020	Screw	1
21	H71G021	Screw	1
22	H71G022	Ball bearing	1
23	H71G023	Bearing holder	1
24	H71G024	Screw	3
25	H71G025	Washer	1
26	H71G026	Screw	1
27	H71G027	Nut	1
28	H71G028	Feed connection crank(right)	1
29	H71G029	Screw	1
30	H71G030	Feed rock shaft bushing	2
31	H71G031	Screw	2
32	H71G032	Collar	2
33	H71G033	Screw	4
34	H71G034	Screw	1
35	H71G035	Feed connection crank(middle)	1
36	H71G036	Link	1

G:LOW SHAFT AND FEED ROCKING MOTION MECHANISM

No.	Ref.No.	Description	Pcs.
37	H71G037	E-type stop ring	2
38	H71G038	Pin	1
39	H71G039	Oil wick	1
40	H71G040	Feed rock shaft	1
41	H71G041	Felt	2
42	H71G042	Oil wick	1
43	H71G043	Clip	1
44	H71G044	Screw	2
45	H71G045	Feed connection crank(left)	1
46	H71G046	Feed bar shaft	1
47	H71G047	Oil wick	1
48	H71G048	Feed bar support	1
49	H71G049	Screw	1
50	H71G050	Screw	1
51	H71G051	Washer	1
52	H71G052	Screw	1
53	H71G053	Felt	1
54	H71G054	Feed bar forked connection	1

H: FEED BAR MECHANISM

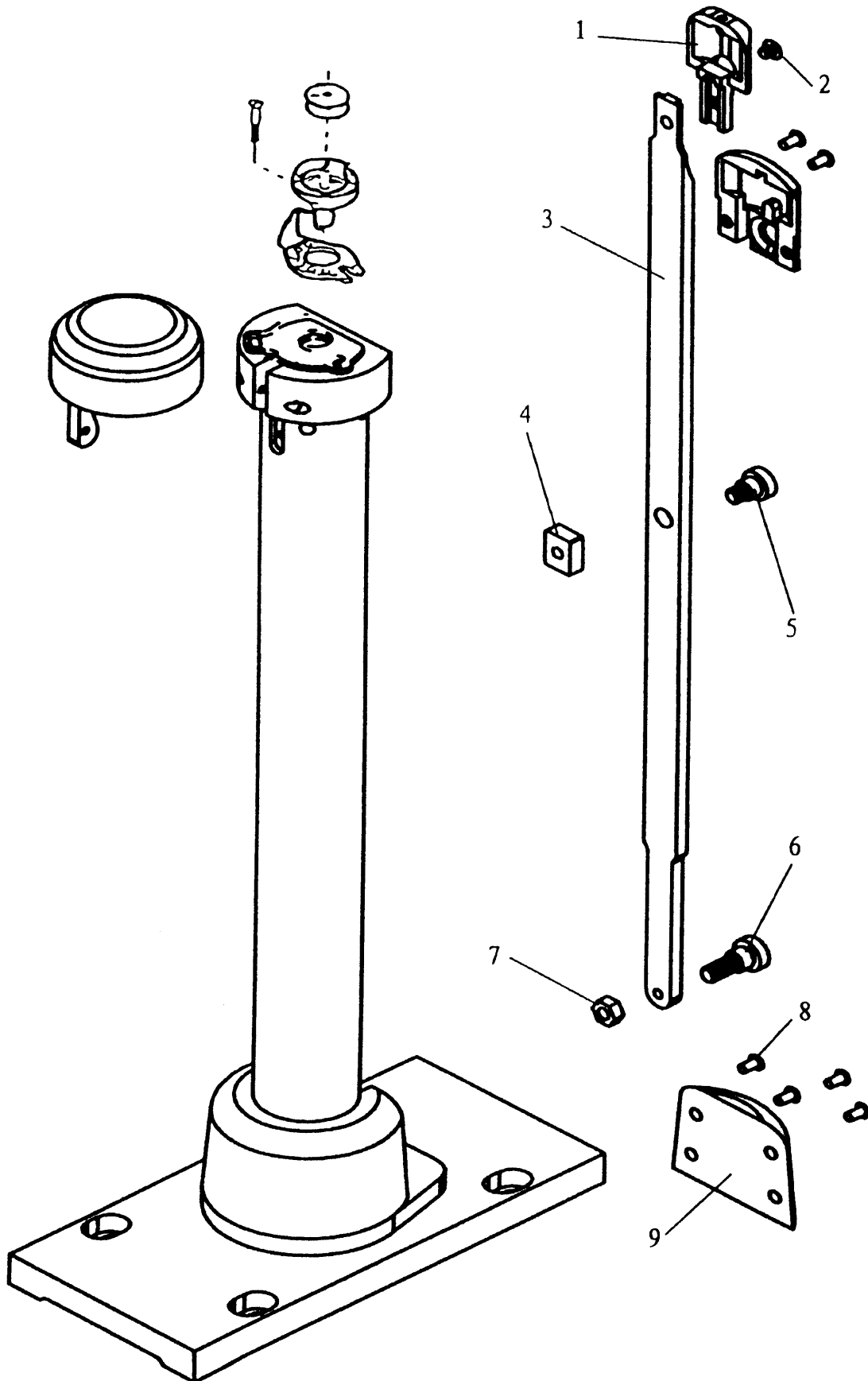

H:FEED BAR MECHANISM

No.	Ref.No.	Description	Pcs.
1	H71H001	Feed dog	1
2	H71H002	Screw	1
3	H71H003	Feed bar	1
4	H/1H004	Square block	1
5	H71H005	Screw	1
6	H71H006	Screw	1
7	H71H007	Nut	1
8	H71H008	Cover	1
9	H71H009	Screw	4

I: HOOK SADDLE MECHANISM

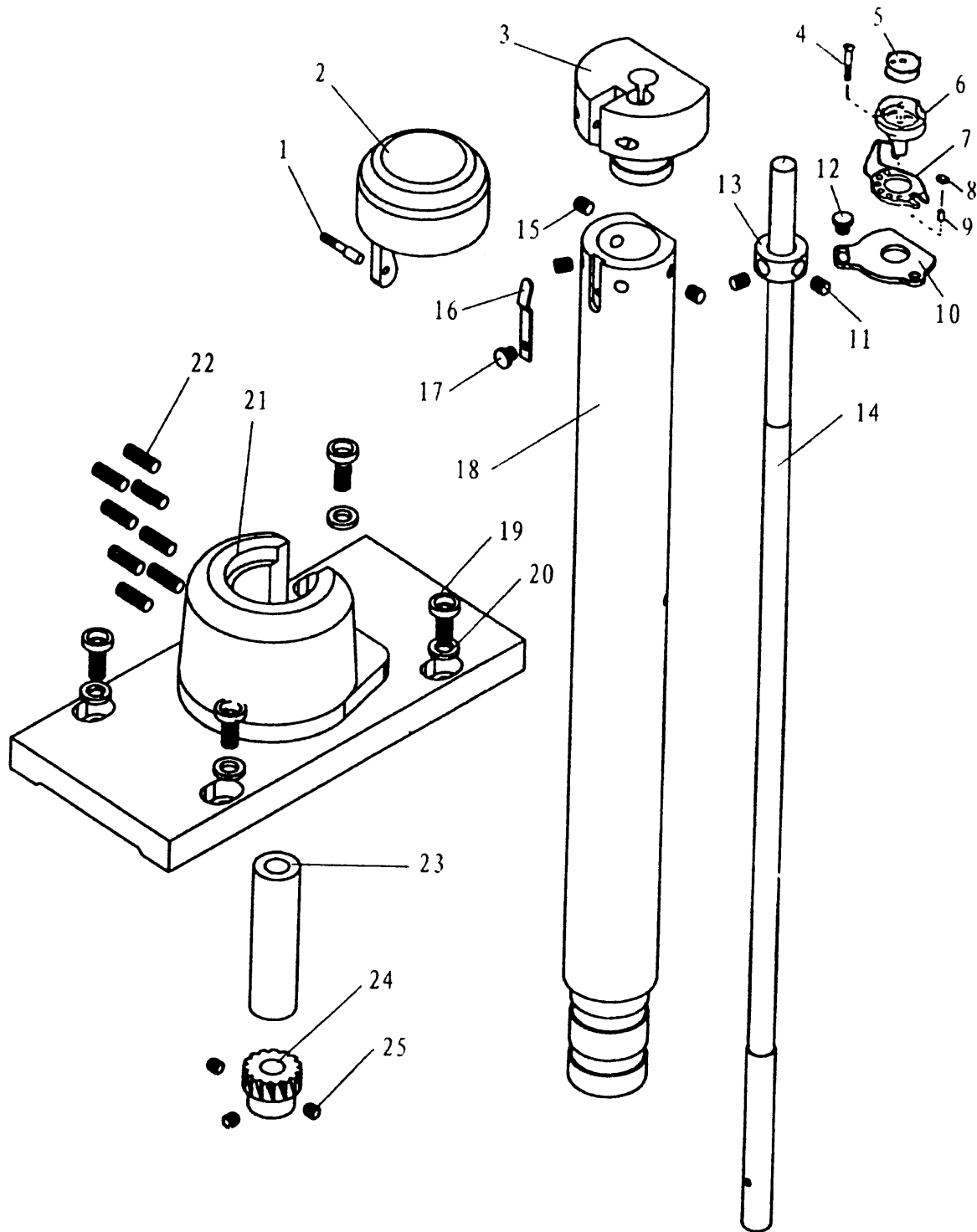

I:HOOK SADDLE MECHANISM

No.	Ref.No.	Description	Pcs.
1	H71I001	Screw	1
2	H71I002	Hook cover	1
3	H71I003	Hook saddle	1
4	H71I004	Screw	3
5	H71I005	Bobbin	1
6	H71I006	Hook complete	1
7	H71I007	Opener	1
8	H71I008	Slide block	4
9	H71I009	Pin	1
10	H71I010	Plate	1
11	H71I011	Screw	1
12	H71I012	Screw	1
13	H71I013	Collar	1
14	H71I014	Hook shaft	1
15	H71I015	Screw	1
16	H71I016	Spring	1
17	H71I017	Screw	1
18	H71I018	Hook saddle post	1
19	H71I019	Screw	1
20	H71I020	Washer	1
21	H71I021	Bracket	1
22	H71I022	Screw	1
23	H71I023	Bushing	1
24	H71I024	Hook driving gear(large)	1
25	H71I025	Screw	1

J: OIL LUBRICATION MECHANISM

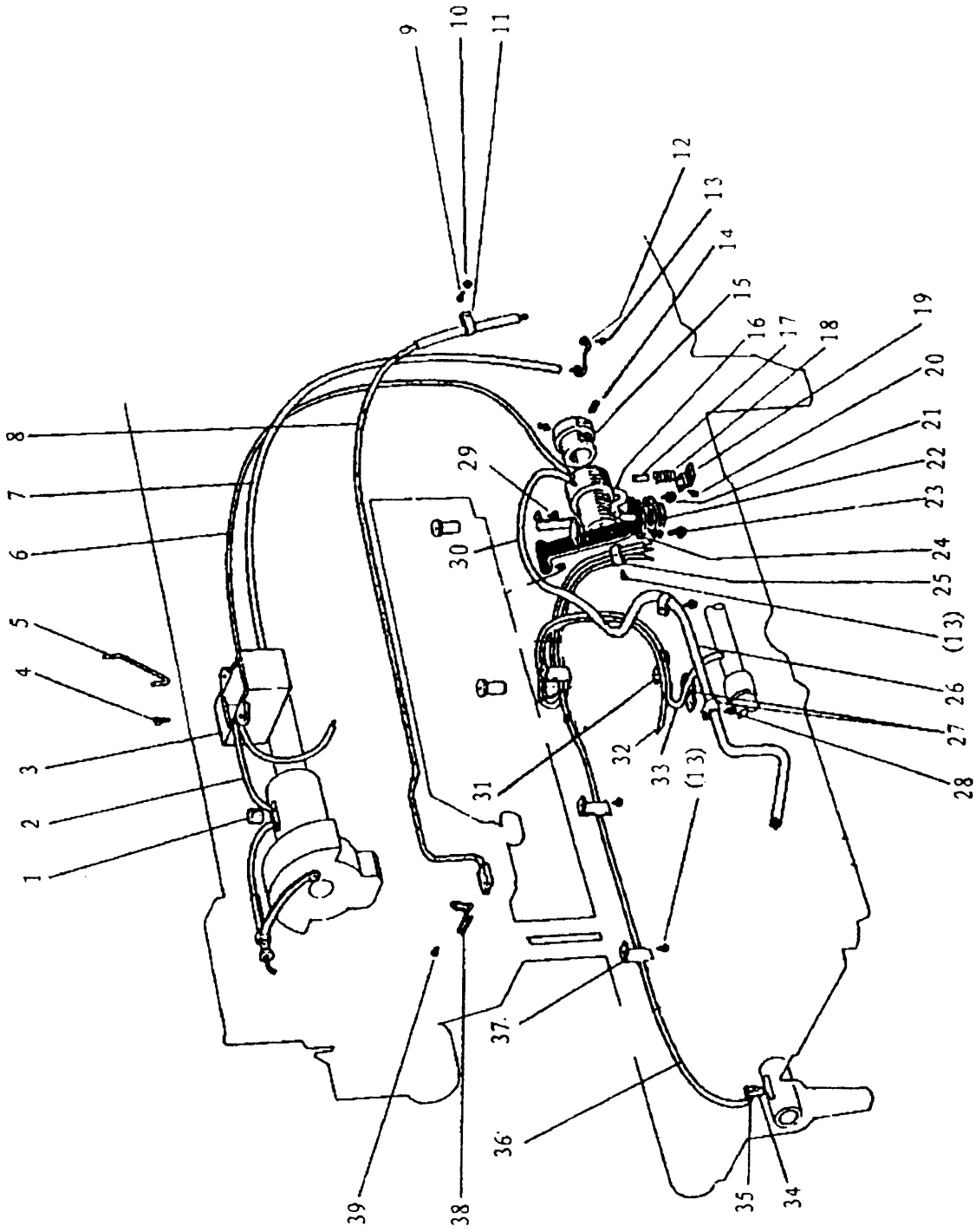

J:OIL LUBRICATION MECHANISM

No.	Ref.No.	Description	Pcs.
1	H71J001	Felt	1
2	H71J002	Oil pipe complete	1
3	H71J003	Oil reservoir complete	1
4	H71J004	Screw	2
5	H71J005	Holder	1
6	H71J006	Oil pipe $\text{\$}\times\text{\$}80$	1
7	H71J007	Oil pipe $\text{\$}\times\text{\$}80$	1
8	H71J008	Oil pipe complete	1
9	H71J009	Screw	1
10	H71J010	Spring washer	1
11	H71J011	Holder	1
12	H71J012	Holder	1
13	H71J013	Screw	8
14	H71J014	Screw	2
15	H71J015	Bushing	1
16	H71J016	Oil pipe	1
17	H71J017	Pin	1
18	H71J018	Spring	1
19	H71J019	Spring holder	1
20	H71J020	Screw	1
21	H71J021	Screw	1
22	H71J022	Filter	1
23	H71J023	Screw	4
24	H71J024	Mounting plate complete	1
25	H71J025	Holder	1
26	H71J026	Oil pipe	1
27	H71J027	Holder	3
28	H71J028	Screw	1
29	H71J029	Screw	1
30	H71J030	Oil pipe $\text{\$}\times\text{\$}30$	1
31	H71J031	Holder	1
32	H71J032	Oil pipe complete	1
33	H71J033	Oil pipe complete	1
34	H71J034	Oil wick	1
35	H71J035	Oil wick	1
36	H71J036	Oil pipe	1

J:OIL LUBRICATION MECHANISM

No.	Ref.No.	Description	Pcs.
37	H71J037	Holder	1
38	H71J038	Screw	1

K: ACCESSORIES

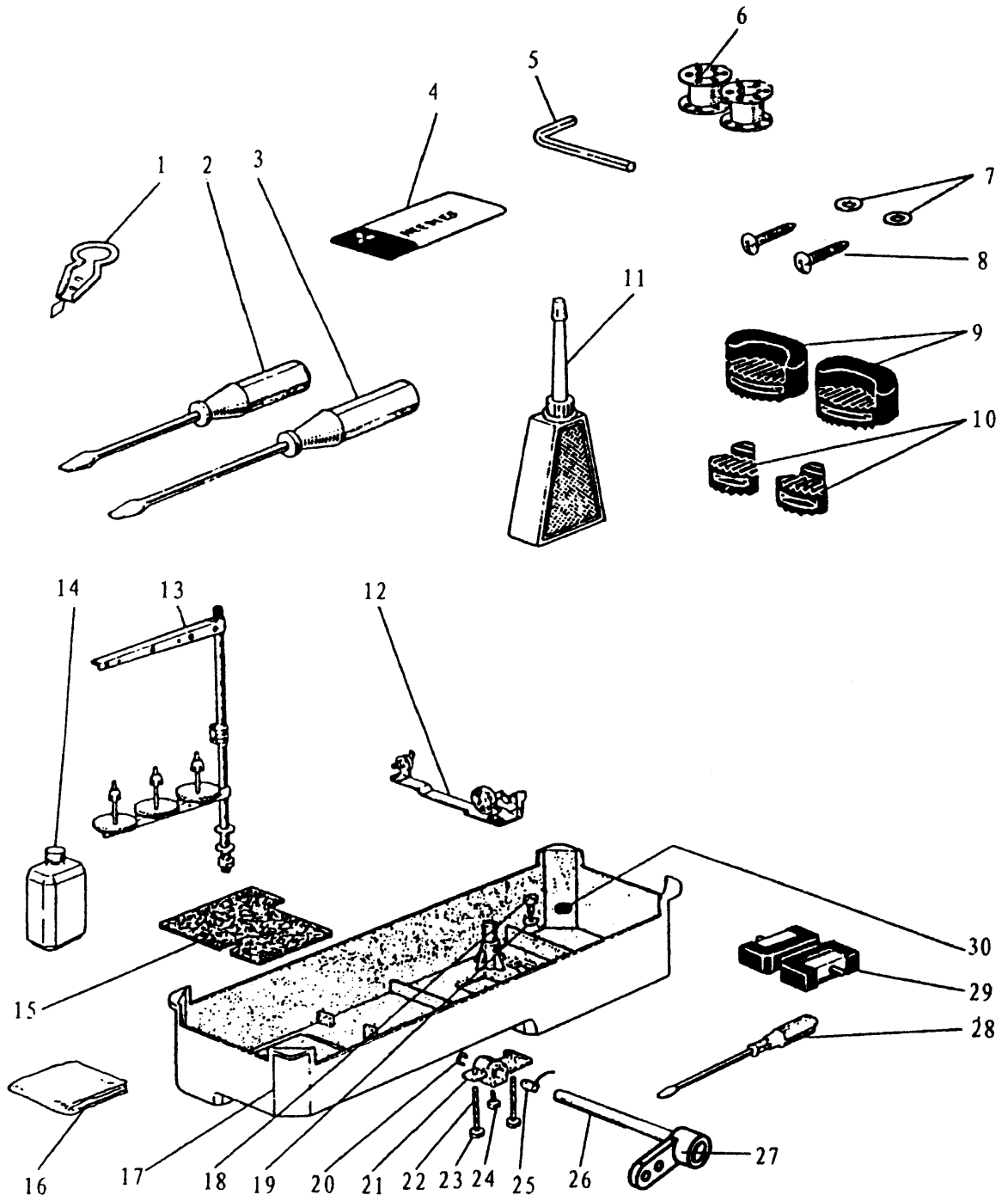

K:ACCESSORIES

No.	Ref.No.	Description	Pcs.
1	H71K001	Thread a needle kit	1
2	H71K002	Screw driver(small)	1
3	H71K003	Screw driver(middle)	1
4	H71K004	needle DP×T-22	3
5	H71K005	Socket wrench	1
6	H71K006	Bobbin	2
7	H71K007	Washer	2
8	H71K008	Screw	2
9	H71K009	Vibration preventing rubber	2
10	H71K010	Vibration preventing rubber	2
11	H71K011	Oiler	1
12	H71K012	Bobbin winder	1
13	H71K013	Cotton stand	1
14	H71K014	Oil can	1
15	H71K015	Felt	1
16	H71K016	Vinyl cover	1
17	H71K017	Oil reservoir	1
18	H71K018	Screw	1
19	H71K019	Washer	1
20	H71K020	E-type stop ring	1
21	H71K021	Knee lifter crank	1
22	H71K022	Screw	1
23	H71K023	Nut	1
24	H71K024	Screw	1
25	H71K025	Spring	1
26	H71K026	Shaft	1
27	H71K027	Link	1
28	H71K028	Screw driver(big)	1
29	H71K029	Small parts	2
30	H71K030	Magnet block for reservoir	1