

GLOBAL

CH 5000 series

**Instruction manual
& spare parts list**

重要安全指示说明

IMPORTANT SAFETY INSTRUCTIONS

为使您正确使用本机，须对本机的各种功能充分了解，以便安全操作。

使用前请仔细阅读使用说明书。我们希望您能长期愉快地使用本机，请保存好说明书，以备查阅。

To get the most out of the many functions of this machine and operate it in safety, it is necessary to use this machine correctly.

Please read this Instruction Manual carefully before use. We hope you will enjoy the use of your machine for a long time.

Please remember to keep this manual in a safe place.

- 1、无论您何时使用本机，须了解基本的安全事项，包括但不限于下列事项。
Observe the basic safety measures, including, but not limited to the following ones, whenever you use the machine.
- 2、通读所有说明，并保存好使用说明书。如果需要，主动脉随时翻阅。
Read all the instructions, including, but not limited to this Instruction Manual before you use the machine, In addition, keep this instruction Manual so that you may read it at anytime when necessary.
- 3、使用本机前，必须弄清与本机有关安全规定，标准在您的国家是否适用。
Use the machine after it has been ascertained that it conforms with safety rules/standards valid in your country.
- 4、使用本机前或使用本机时，所有安全装置必须配备齐全。机器运转时，无安全装置属违章操作，决不允许。
All safety devices must be in position when the machine is ready for work or in operation. The operation without the specified safety devices is not allowed.
- 5、操作人员必须经过适当的培训。This machine shall be operated by appropriately-trained operators.
- 6、为了您的人身安全，我们建议您戴上防护眼镜。
For your personal protection, we recommend that you wear safety glasses.
- 7、下列情况下，请关闭电源开关或拔下电源插头。
For the following, turn off the power switch or disconnect the power plug of the machine from the receptacle.
7-1 机针穿线。
For threading needle (s).
7-2 更换机针、压脚、针板、送料牙、布料导板等。
For replacing part (s) of needle, presser foot, throat plate, feed dog, cloth guide etc.
7-3 进行维修时。
For repair work
7-4 操作区域无人时。
When leaving the working place of when the working place is unattended.
- 8、在机器加油润滑时，若不小心让油碰到眼睛、皮肤或咽下机油或润滑油，请立即冲洗被沾染部位或去医院检查。
If you should allow oil, grease, etc. Used with the machine and devices to come in contact with your eyes or swallow any of such liquid by mistake, immediately wash the contacted areas and consult a medical doctor.
- 9、无论机器运转与否，严禁乱动机器零部件和配套装置。
Tampering with the live parts and devices, regardless of whether the machine is powered, is prohibited.
- 10、机器的维修、改造和调整等工作必须由专业技术人员进行。
Repair, remodeling and adjustment works must only be done by appropriately trained technicians or specially personnel.

11、应由专业受训人员进行一般的维修和检验工作。

General maintenance and inspection works have to be done by appropriately trained personnel.

12、必须在专业电器人员或专业技术人员的指导下进行有关电器部件的维修，任何电器部件一经发现受损，立即停止机器运转。

Repair and maintenance works of electrical components shall be conducted by qualified electric technicians or under the audit and guidance of specially skilled personnel.

13、使用期间要定期全面彻底清洗机器。Periodically clean the machine throughout the period of use.

14、正常操作本机时，必须进行试运转，工作环境远离强噪音源，如高频电焊机等。

Grounding the machine is always necessary for the normal operation of the machine. The machine has to be operated in an environment that is free from strong noise sources such as high-frequency welder.

15、由电器人员选择合适的插头和有地线的插座。

An appropriate power plug has to be attached to the machine by electric technicians, Power plug has to be connected to a grounded receptacle.

16、若需要改造或改进本机，请采用有效可行的安全措施。本公司对由此而产生的伤害不承担责任。

The machine is only allowed to be used for the purpose intended. Other used are not allowed.

17、本机只适用于专业缝纫。

Remodel or modify the machine in accordance with the safety rules/standards while taking all the effective safety measures. We assures no responsibility for damage caused by remodeling or modification of the machine.

18、两种警告提示符 Warning hints are marked with the two shown symbols.



操作人员或维修人员请注意 Danger of injury to operator or service staff



特别注意事项 Items requiring special attention

安全操作事项 FOR SAFE OPERATION



1、为避免触电，请不要打开电机的电箱盖，也不要触摸电箱内部组件。

To avoid electrical shock hazards, neither open the cover of the electrical box for the motor nor touch the components mounted inside the electrical box.



1、为避免人身伤害，移动皮带罩，护手挡或安全装置时，请不要开动机器。

To avoid personal injury, never operate the machine with any of the belt cover, finger guard of safety devices removed.

2、为尽可能避免机器运转造成的人身伤害，手指、头部和衣服应远离上轮、皮带和电机周围不要放置任何物品。

To prevent possible personal injuries caused by being caught in the machine. Keep your fingers, head and clothes away from the handwheel, V belt and the motor while the machine is operation. In addition, place nothing around them.

3、为避免人身伤害，当您打开电源开关或操作机器时，切勿将手放在机针下方。

To avoid personal injury, never put your hand under the needle when you turn "ON" the power switch or operate the machine.

4、为避免人身伤害，机器运转时，切勿将手放入挑线罩内。

To avoid personal injury, never put your fingers into the thread take-up cover while the machine is in operation.

5、弯针高速运转时，勿将手指放在弯针附近。另外，换弯针时，请关掉机器电源开关。



The looper rotates at a high speed while the machine is in operation, To prevent possible injury to hands, be sure to keep your hands away from the vicinity of the looper during operation. In addition, be sure to turn OFF the power to the machine when replacing the looper.

6、为尽可能避免人身伤害，当翘起或抬升机头时，勿将手指放入机器内部。
To avoid possible personal injuries, be careful not to allow your fingers in the machine when tilting/raising the machine head.

7、为尽可能避免机器的突然启动所造成的事故，抬起机头或移动皮带罩或皮带时，请关掉机器的电源。

To avoid possible accidents because of abrupt start to be machine, turn OFF the power to the machine when tilting the machine head or removing the belt cover and the V belt.

8、如果你的机器配用伺服电机，机器未运转时，电机无噪音。为避免机器的突然启动所造成的事故，请关掉机器的电源开关。

If your machine is equipped with a servo-motor, the motor does not produce noise while the machine is at rest. To avoid possible accidents due to abrupt start of the machine, be sure to turn OFF the power to the machine.

9、为避免触电，移动电源地线时，请勿让机器运转。

To avoid electrical shock hazards, never operate the sewing machine with the ground wire for power supply removed.

10、为尽可能避免触电或电器组件受损，在插上或拔下插头之前，请关掉电源开关。

To prevent possible accidents because of electric shock or damaged electrical component(s), turn OFF the power switch in prior to the connectriion/disconnecti on of the power plug.

目 录

Contents

一、机器规格 Specification	1
二、开车前注意事项 Pre-start checks	2
三、使用注意事项 Operating instructions.....	2
四、机器的安装 Installation of the machine.....	2
五、加油 Oiling	3
六、面部油量调节 How to regulate oil amount by means of manipulating elements on the face plate	3
七、机针的安装 Setting-up of the needle	3
八、面线的穿法 The threading of needle thread	4
九、底线的穿法 The threading of bobbin thread.....	4
十、夹线器 Thread tension asm.	4
十一、压脚 Presser foot	5
十二、针距的调节 To adjust stitch length	5
十三、压脚高度的调节 Adjustment of the height of the presser bar	6
十四、送料牙的调节 Adjustment of the height of the feed dog	6
十五、送料牙与针的同步 The timing of feed dog and needle	6
十六、针杆高度的调节 Adjustment of the height of needle bar	6
十七、机针和弯针的调节 Adjustment of the needle and looper	6
十八、弯针相对机针的同步 The timing of looper in rererence to needle	7
十九、弯针的勾取量 Thread-guiding amount of the looper	7
二十、弯针和机针间的间隙 The clearance of looper and needle	8
二十一、保针架的同步 The timing of needle guard	8
二十二、保针架的位置 Position of needle guard	8
二十三、底线打线凸轮 Looper thread take-up cam.....	8
二十四、挑线杆线量调节板的位置 The position of thread-amount adjusting plate of the thread take-up lever ..	9
二十五、中间导线钩 Frame thread eyelet	9
二十六、针板的调换 Replacement of throat plate	9
二十七、缝纫机的保养 Maintenance of the machine	10
二十八、故障和措施 Common breakdowns and measures of trouble shooting	10

操作前的注意事项 BEFORE OPERATION

注意:

为避免机器受损或发生事故, 切记如下:

为您初次使用本机前, 请彻底清洗, 除掉运输过程中的全部灰尘, 并充分加油润滑。

- 确认电压是否正常, 插头与电源连接是否正确。
- 若你的国有的电压与本机器设计电压不一致, 请勿使用本机。
- 确认电机转动方向是否正确。
- 使用本机的第一个月, 机器应在低于正常转速下运转。

CAUTION:

To avoid malfunction and damage of the machine, confirm the following:

- Before you put the machine into operation for the first time after the set-up, clean it thoroughly.

Remove all dust gathering during transportation and oil it well.

- Confirm that the voltage has been correctly set.

Confirm that the power plug has been properly connected to the power supply.

- Never use the machine in the state where the voltage type is different from the designated one.

- Confirm that the direction of rotation of the motor pulley is correct.

- Operate your machine at the less of sewing speed in the first month.

一. 机器规格 Specification

线迹形式	并列双针双线链式缝	纵列双针双线链式缝	单列单针双线链式缝	三针链式缝
速度	最高每分钟5500转			最高每分钟3500转
针迹长度	1/16"~5/32"(1.4~4mm)			
针杆行程	30mm			
双线间距范围	1/8" 5/32" 3/16" 7/32" 1/4" 5/16" 3/8" 1/2"	3/16"		1/8" × 2
挑线形式	针杆挑线			
缝机(机针)	TV × 79#~21#			
弯 针	独立调节式样1/8"~1/2"通用			
保 针 架	摇动式、固定式使用			
膝提压脚	上升量 8~10mm			
供 油	叶轮泵			
润 滑 油	2号白油			

Stitch type	Two-needle double-row chain stitch	Two-needle double-line chain stitch	One-needle single-row chain stitch
Speed	Max. 5500 s.p.m		
Stitch length	1/16" ~5/32" (1.4~4mm)		
Stroke of needle bar	30mm		
Gauge of double-row Chain stitch	1/8" 5/32" 3/16" 7/32" 1/4" 5/16" 3/8" 1/2"	3/16"	
Thread take-up type	Needle bar thread take up type		
Needle	Tv × 7 9#~21#		
Looper	Separately adjustable type, for the range of 1/8" to 1/2"		
Needle guard	Oscillating type and rigid type		
Light clearance of knee lifter	8~10mm		
Oil supply	Impeller-type pump		
Lubricating oil	#2 while oil		

二. 开车前的注意事项 Pre-start check

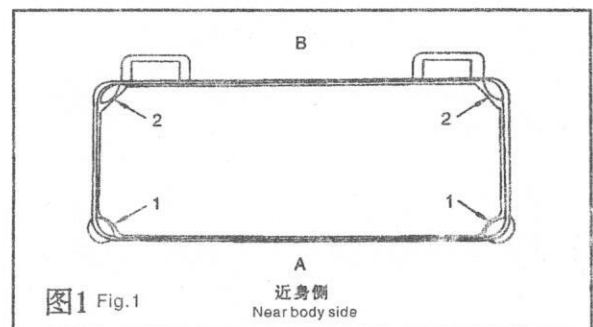
- 1、油盘内未加油绝不能开车。
 - 2、机器运转时，从上轮外侧看转向应为逆时针方向，注意，不能倒转。
 - 3、在最初使用的第一个月中，应把缝速降为每分钟4500针进行缝纫作业。
 - 4、按照电动机标牌上的标注，检查电源，电压及单相、三相是否正确。
- 1) The machine shall not be started running until the completion of oiling.
 - 2) The rotating direction of the balance wheel, when the machine is started running, shall be in counter-clockwise one. (View from the right side of the balance wheel.) A warning shall be given in advance against making the machine run while balance wheel turning clockwise.
 - 3) The machine shall be under operation at less than 4,500 S.P.M. For the first month.
 - 4) Check power source, voltage, and phase number to see whether they are in accordance with the ratings on the name plate of the motor to be used.

三. 使用注意事项 Operating instructions

- 1、机器运转时，请勿将手放到针的下部。
 - 2、机器运转时，请勿将手指伸入挑线杆护罩内。
 - 3、机器确已停止后，才能盘动上轮。
 - 4、关掉电动机开关后，由于惯性上的缘故，电动机还会继续旋转一段时间，所以要注意，未停止转动不能将机器倾倒。
 - 5、机器运转时，请勿将手指、头发或其它东西靠近或接触上轮、“V”形皮带、电动机，也不要把东西放置在它们附近。
 - 6、装拆皮带罩及护指器时，请勿开动机器，更不得在将皮带罩卸下的状态下开动机器。
- 1) Do not put your hands under the lower part of the needle when the machine is running.
 - 2) Do not put your fingers into the thread take-up lever cover when the machine is running.
 - 3) Only when the machine stops can you turn the balance wheel by hand.
 - 4) After the motor switch being turned off, due to inertia, the motor will continue to rotate for a while. Be careful not to have the machine tilted unless it stops.
 - 5) Keep away from the balance wheel, V-belt, winder and the motor.
 - 6) Do not start running the machine during mounting or replacing the belt cover, finger guard, etc.

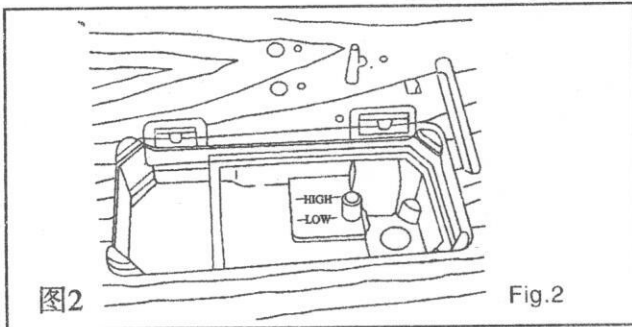
四. 机器的安装 (图1) Installation of the machine (Fig.1)

- 1、将油盘支座1套在油盘近身侧(A边)，将油盘座垫套在油盘B侧，再将油盘连同座套一起放入机架中。
 - 2、将机头连接钩插入底板孔内，与台板的机头连接钩座相嵌合，再将机头放到四只角的缓冲垫上。
1. Nail the rubber washer on the operator's side of the table, lever the washers on the other side (B) then place the oil reservoir on top.
 2. Put the machine connecting hooks into the holes to engage respectively two hinges seated in the table, then place the machine on the four cushions.

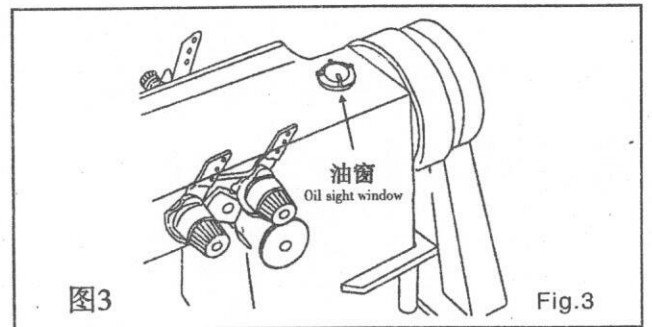


五. 加油 (图2.图3) Oiling(Fig.2,3)

- 1、向油盘内加缝纫机油(2号白油)至HIGH记号部位(图2)
- 2、如果油面低于LOW记号,应再加油。
- 3、加油后开动机器,润滑正常时,应看到油液喷到油窗上(图3)。至于喷到油窗上的油量多少与总油量的多少有关,所以不必担心。
- 4、如需换新油,只要拆下油盘的排油螺钉,污油就能排出。
- 5、使用新机器活长期未使用的缝纫机时,需抬起压脚以每分钟3500~4000针的速度空转约10分钟。



1. Oiling shall be made in oil reservoir and the oil surface also be made to level the mark "High" before the machine is started running (Fig.2)
2. Oiling shall be kept on until the oil surface has been brought above the mark "Low" (Fig.3)
3. The normal condition of lubrication is that the oil shall spray onto the oil sight. The amount of oil spraying onto the oil sight is not at all proportional to the total amount of oil in the oil reservoir. There is nothing to worry about.
4. Only when the drain cover screw is loosened and taken off can old oil be drained out and new oil is supplied again.
5. When a new model or those standing idle for long time is to be operatedm presser foot shall be lifted and run idle for about ten minutes.



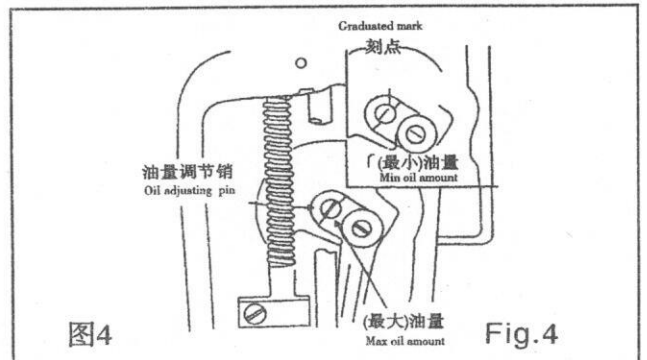
六. 面部油量调节 (图4)

How to regulate oil amount by means of manipulating elements on the pace plate(Fig.4)

转动油量调节销,可以调节针杆连杆销的供油量,调节销的刻点,靠近针杆连杆销时,油量最小,反之,则油量最大(图4)

注意:调节油量时要十分注意,供油量并不是随调节立刻变化的。

To turn oil-amount adjusting pin to regulate oil amount of the thread take-up crank, min. Oil amount will be supplied when the mark of adjusting pin moves to the thread take-up crank as near as you desire. Otherwisem, max. Oil amount will be supplied.

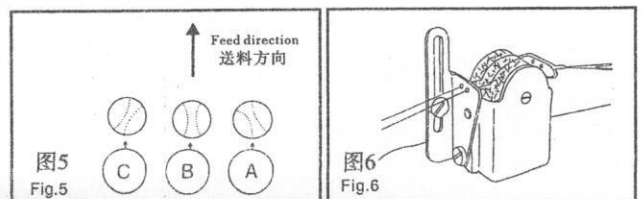


七. 机针的安装 (图5.图6) Setting-up of the needle (Fig.5,6)

机针请使用TV×7的9#或21#型机针,装缝针时应使对应的针孔心缝料送料方向一致如图5中B。特别是在使用化纤线时,机针针孔的方向不能如(图5)中C的方向安装。

用化纤线缝制时,可按(图6)所示形式放置硅油,油箱应另外定制。

When thread of chemical fibre is used, the direction of the needle eye shall not be in that one, as shown in part C of Fig.5. Needle types to be desired fall within the range of #9 to #21 of TV×7; Oil tank shall be custom-made when thread of chemical fibre is used; silicone oil can be placed like that, as indicated in Fig.6.



八. 面线的穿法 (图7) The threading of needle thread.(Fig.7)

在针杆上升到最高位置时,按图7所示顺序依次穿过各线孔。

1. 线从操作者一侧向外穿过机针。
2. 面线穿过机针后必须再拉出100mm长线头。

To thread the eyes of the needles in the order as shown in Fig.7:

- 1) To make thread go through the eye of the needle outwards. (View from the operator's side)
- 2) To pull out 100mm of the remaining thread after needle thread going through the eyes of the needles.

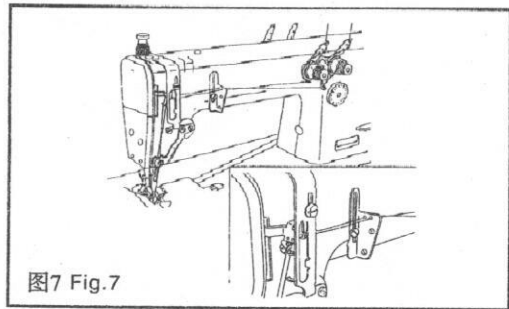


图7 Fig.7

九. 底线的穿法 (图8. 图9) The threading of bobbin thread (Fig.8,9)

底线按图示顺序依次穿过各线孔。

- 1、按 (图8) 所示穿过夹线器单面导线板, 如用捻度大的线或缝纫时需送料距大的时候应穿二个孔。
- 2、把 (图9) 中的扳簧朝操作人员侧拉, A就向上抬起。
- 3、穿弯针线时, 用附件中的镊子按图所示将线穿过, 在弯针的前端拉出50mm长线头。

To make bobbin thread going through the eye of the needle in the order as shown in (Fig.8 and 9)

- 1) Make the bobbin thread go through the tension guide plate; go through the two holes when thread of harder twist fibre is used and feed gauge is wider than usual.
- 2) Pull the spring toward the operator, as shown in Fig.9 and part A will rise upwards.
- 3) When threading the looper, the thread shall be made go through the eye of the needle with a tweezer as shown in Fig.9 and 50mm of remaining thread be pulled out.

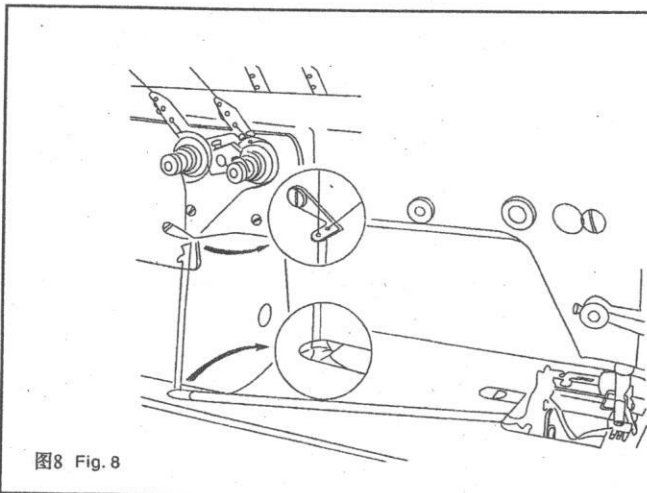


图8 Fig.8

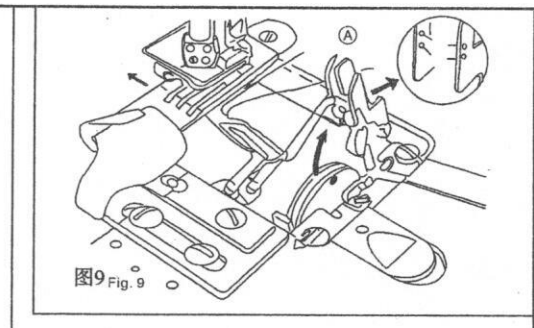


图9 Fig.9

十. 夹线器 (图10. 图11. 图12) Thread tension asm. (Fig.10,11,12)

面线张力的调节 (图10所示): 向右转动夹线螺母张力变大。

底线张力的调节 (图11所示): 向右转动夹线螺母张力变大。

底面线的关系 (图12所示) 为链式线迹的形成。

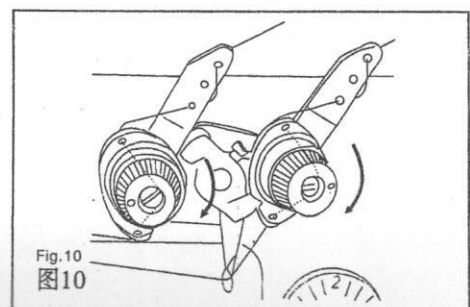


Fig.10
图10

To adjust needle thread tension is accordance what sewing working condition, we can adjust needle thread tension by tension spring. Turn the tension nut clockwise to increase the tension; turn counter-clockwise to decrease the tension.

To adjust bobbin thread tension:

Turn tension screw clockwise to increase the tension; turn tension screw counterclockwise to tension; turn Tension screw counterclockwise to decrease the tension.

The relation between the needle thread and the bobbin thread as shown in (Fig. 12) depicts the forming of chain stitch.

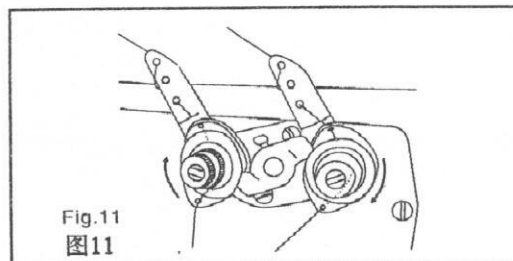


Fig.11
图11

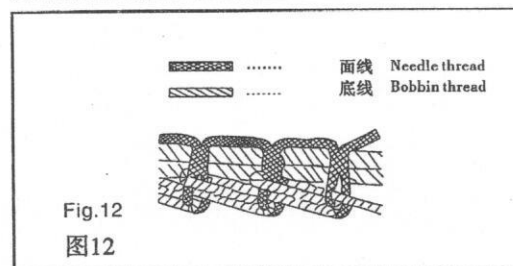


Fig.12
图12

十一. 压脚 (图13.14) Presser foot (Fig.13,14)

压脚压力的调节 (图13): 顺向转动压脚调压螺钉, 压力增强, 反之则压力减弱, 对一般布料而方, 压脚调钉的标准高度为37~30mm (此时压脚压力约为5kg) 左右。要使压脚保持在抬起位置, 只要把压脚扳手向左或向右转动90° 即可 (图14)

Adjustment of pressure on presser foot (Fig.13)

Turn pressure regulating thumb screw clockwise to increase the pressure; turn pressure-regulating thumb screw counter-clockwise to decrease the pressure. For general fabric the standard height of pressure regulating thumb screw is about 27-30mm (5kg)

The presser bar lifter shall be turned either leftward or rightward in order to keep the presser foot under the condition of lifting position.

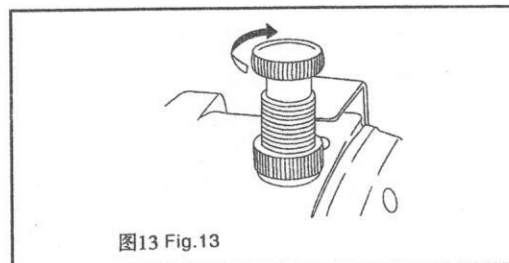


图13 Fig.13

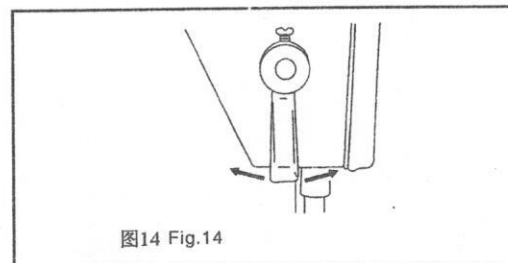


图14 Fig.14

十二. 针距的调节 (图15) To adjust stitch length (Fig.15)

- 1、针迹长度的调节 (图15) 只要旋转针距调节旋钮至所需数字即可。旋钮上刻度的数字用mm表示。
- 2、针迹从大到小改变送料刻度时, 应一边将倒送料扳手朝下压; 一边转动送料距旋钮。
- 3、针迹长度最大是4mm, 最小是1.4mm。
- 4、按下倒送料扳手, 针迹变为紧密缝 (1.4mm), 该功能可用于起始缝和终止缝或需加强缝纫的部分。
- 5、本机不能进行倒缝。

1. Turn feed regulating dial to the figure desired. The value of graduation is shown in millimetre(mm).
2. If you intend to change the stitch length, press down the reverse feed lever while turning the feed regulating dial.
3. Max. stitch length is 4mm: Min. stitch length is 1.4mm.
4. When reverse feed lever is pressed down, tight-needle stitch of 1.4mm will be formed; this version of stitch is suitable for beginning and end seaming or partaking.
5. The machine can not make reverse stitching.

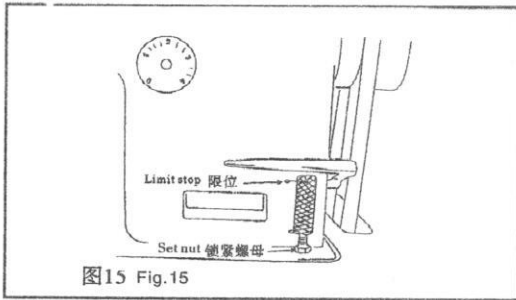


图15 Fig.15

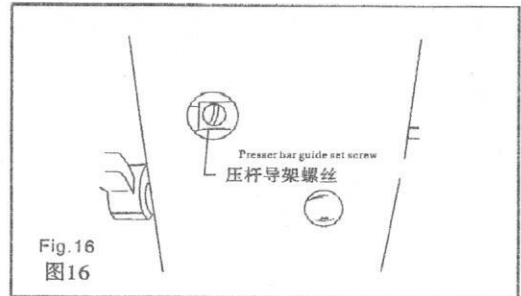


Fig.16
图16

十三. 压脚高度的调节 (图16) Adjustment of the height of the presser bar (Fig.16)

为了调换压脚或改变压脚高度、角度需要;

- 1、拆下面板上的孔塞 (图16)
- 2、旋松压杆导架的紧固螺钉进行调节。
- 3、调节后旋紧紧固螺钉。

For the requirements of either replacing the presser foot or changing the height and angle of presser foot, the following shall be observed:

1. Take off the rubber plug in the hole from the face plate, as shown in Fig.16.
2. Loosen the presser bar guide bracket set screw.
3. After adjusting, retighten the screw.

十四. 送料牙的调节 (图17, 18) Adjustment of the height of the feed dog (Fig.17,18)

旋松 (图18) 所示螺钉②, 送料牙的倾角即可调节成标准型、A型、B型, 送料牙最大突出量是0.8mm, 用 (图17) 中螺钉①调节。

Loosen the set screw ②, as shown in Fig.18, the angle of the feed dog can be adjusted to the specified one of standard version, A version, and B version. The Max. Height of 0.8mm of the projection from dog is adjustable by the adjusting of screw ① as shown in Fig.17.

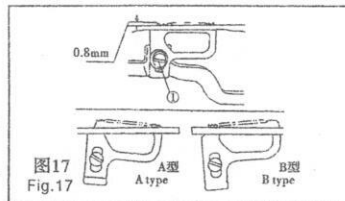


图17
A type B type

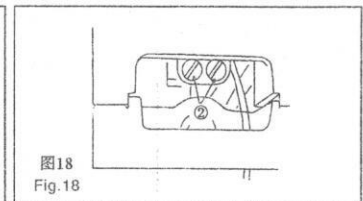


图18
Fig.18

十五. 送料牙与针的同步 (图19) The timing of feed dog and needle (Fig.19)

针尖下降至针板上平面3mm时, 送料牙刚好全部下降至针板上平面以下, 此时正好同步。可调节 (图19) 中的螺钉。 When the point of needle lowering down to the location of 3mm from the upper surface of the throat plate, the feed dog is right at the position below the upper surface of the throat plate, viz. The running of feed dog being well regulated in relation to the motion of needle.

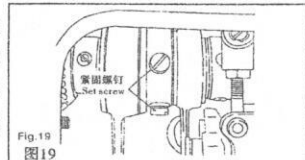


图19
Fig.19

十六. 针杆高度的调节 (图20) Adjustment of the height of needle bar (Fig.20)

使用TV×7机针时, 可用针杆上的刻线, 针杆在下死点时, 针杆上刻线应对准针杆下衬套的下端面。(如图20所示)

When the needle of TV×7 is used, if the graduation on the needle bar is at the bottom dead centre, the mark of graduation shall be in line with the lower end of the needle bar bushing, lower, as indicated in Fig.20.

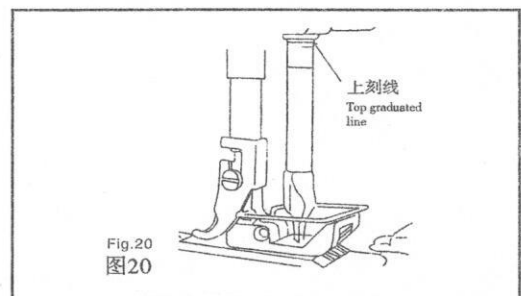


图20
Fig.20

十七. 机针和弯针的调节 (图21, 图22) Adjustment of the needle and looper (Fig.21, 22)

弯针前后运动量的调节;

按如下顺序调节可得弯针椭圆运动中 (图21) 所示的B尺寸, 通常B的尺寸在最大时为3.7mm, 各种规格的机针都能缝纫。

1. 拆下弯针曲柄罩壳上的橡胶塞 (图22)

Adjustment of forward & backward motion of the looper: The dimension of part B of the looper in an elliptic motion can be measured, (refer to Fig.21). The max. dimension of part B is usually 3.7mm, suitable for sewing operation of needles of all kinds of sizes.

The adjusting procedure is as follows:

- 1) Take off the rubber plug on the crank case of the looper (refer to Fig.22)

2. 用手转动上轮。
3. 先旋松定位螺钉和紧固螺钉，调节有标号的螺钉。
4. 把调节螺钉上的冲印标记向右旋转，则B的尺寸就会变大，反之变小。
5. 旋紧固定螺钉和紧固螺钉。

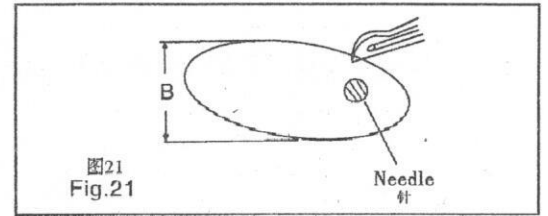


图21
Fig.21

- 2) Turn the balance wheel by hand.
- 3) First loosen set screw and positioning screw, and then adjust marked screw.
- 4) Turn clockwise the adjustable screw on which punch mark is printed, and the dimension of part B will be increased in value.
- 5) Tighten set screw and positioning screw.

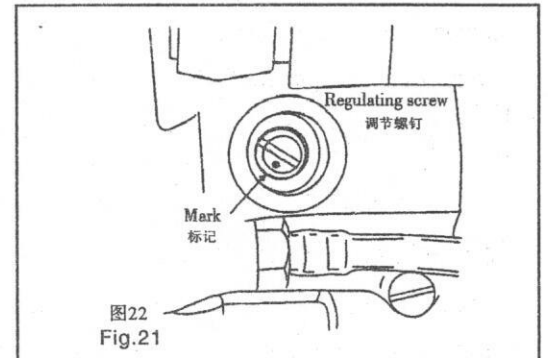


图22
Fig.21

十八. 弯针相对机针的同步 (图23) The timing of looper in reference to needle (Fig.23)

机针在最低点时，弯针退到最后，旋松图示齿轮的螺钉进行同步调整（如图23）。
The looper shall be moved backward to the lowest position while the needle is at the bottom dead centre; loosen the screw on the gear and make timing adjustment of the looper in relation to the needle (refer to Fig23.)

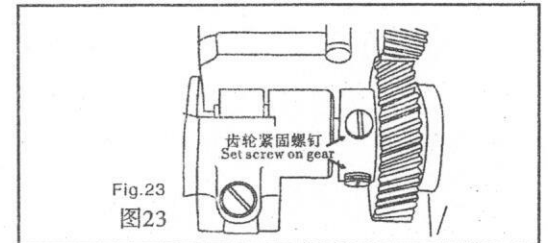


Fig.23
图23

十九. 弯针的勾取量 (图24) Thread-guiding amount of the looper (refer to Fig.24)

1. 弯针的针尖到达机针的中心位置时，弯针针尖离机针孔上端的距离标准值是2mm，此时针杆下刻线和针杆下衬套下端面对齐。（如图24）
2. 弯针的后退量约3.5mm。
3. 机针孔和弯针孔的相对关系如（图24）所示。（左右弯针可以分别调整）

- 1) The standard value of the vertical distance of the point of the looper away from the upper end of the eye of the needle is 2mm, then the graduation mark on the lower part of the needle bar shall be in line with the lower end of the needle bar bushing, lower. (Refer to Fig.24)
- 2) The value of the stroke moved backward by the looper is about 3.5mm.
- 3) The relation between the eye of the needle and the eye of the looper is indicated in Fig. 24. (Note that the left looper and the right one can be separately adjusted.)

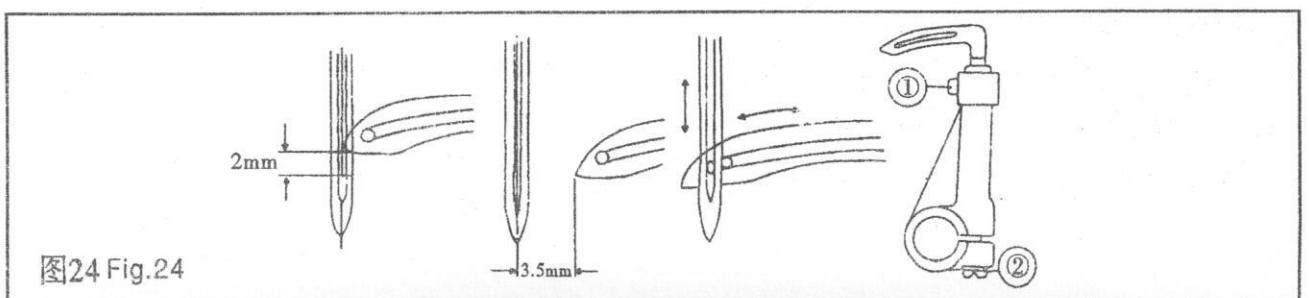


图24 Fig.24

二十. 弯针和机针间的间隙 The clearance of looper and needle

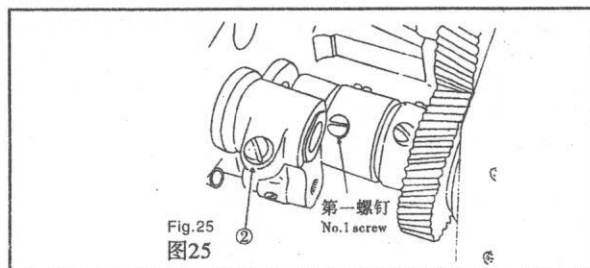
保针架调整后, 机针和弯针间应留有一定间隙, 即用手指轻压机针, 机针也不应碰到弯针针尖。如果间隙太小了, 机针的侧面与弯针针尖就会因相互碰撞而损伤。

After adjusting the needle guard, the clearance of a given value between the needle and the looper shall be kept unchanged; the needle shall not touch at the point of the looper when it is pressed down softly. If the clearance is narrower than usual. The side of the needle and the point of the looper are apt to incur breakage due to the impact of the needle side against the looper point.

二十一. 保针架的同步 (图25) The timing of needle guard (Fig.25)

保针架的同步, 由(图25)中第一螺钉旋入弯针轴上的平面而决定。

The timing of the needle guard depends on the condition of the plane on the rock shaft of the looper when no.1 screw has been screwed into this rock shaft.



二十二. 保针架的位置 (图26) Position of needle guard (Fig.26)

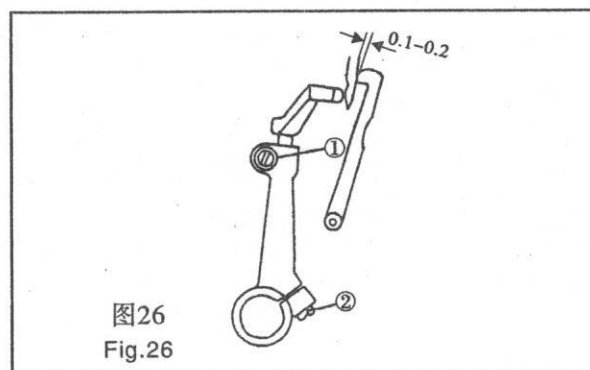
摆动保针架位置, 使弯针勾取面线时让机针的针尖轻轻触及保针架, 其高度应调整到不触及固定保针架范围, 旋松(图26)中螺钉①②即可进行调节。

Oscillating the needle guard to make the needle tip contact with needle gauge slightly.

It is recommended that the height adjustment shall not fall within the area of the left counter needle guard. The adjustment can be made by loosening screw ① and ②. The relation between left counter needle guard and the counter needle guard is as represented in Fig 26; the clearance from the needle falls within the range of 0.1 to 0.2mm.

Note that the forced clamp of the needle shall be prohibited when the machine is in motion.

固定保针架和摆动保针架之间的关系(如图26)所示, 与机针的间隙为0.1~0.2mm, 缝纫机运转时不能强行夹住机针。



二十三. 底线打线凸轮 (图27) Looper thread take-up cam (Fig.27)

底线打线凸轮的位置如(图27)所示, 针杆在最高点时, 打线凸轮平面部分和钢丝平行部分的夹角为 18° ~ 20° , 旋松螺钉B进行调整, 位置决定后再旋紧。

调整时请注意下列事项: 底线从打线凸轮的突端A脱出时, 针尖要完全进入底线弯针的线环中。

Its position can be seen as shown in Fig.27 when the needle bar is at the top dead centre, the planes of the cam and steel wire are in parallelism; the projecting part of the cam can slightly rise at the angle of 18 to 20 degrees. First loosen screw B, and then make adjustment, finally tighten the make adjustment, finally tighten the screw firmly. Pay close attention to the following; the needle tip shall entirely come into the thread loop of the looper when the bobbin thread rejecting from the projecting part of the cam.

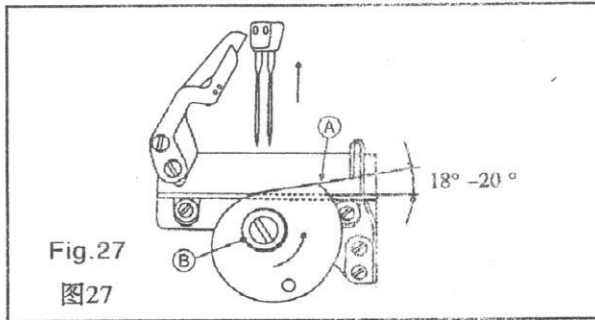


Fig. 27
图27

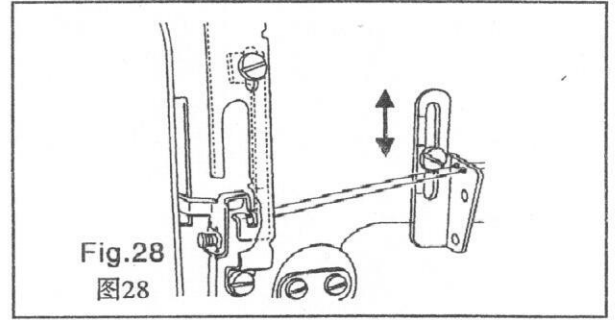


Fig. 28
图28

二十四. 挑线杆线量调节板的位置 (图28)

The position of the thread-amount adjusting oplate of the thread take-up lever (Fig.28)

针杆在最低点时, 如 (图28) 所示, 用挑线杆线量调节板挡住面线, 这样勾取面线时, 面线线环变大。

此外, 针杆在最低处时, 也有拉紧面线线环的作用, 通常在使用较细的缝线时, 应把线量调节板降到最低点。

The thread-amount adjusting plate will retain the bobbin at thread when the needle bar is the bottom dead centre; in such a way the loop of the needle thread is to become bigger when the needle thread is hooked. In addition to the foregoing there is a function of the tight pulling of the needle thread loop. The thread-amount adjusting plate usually reduces to the lowest point when a thread finer than normal is used.

Note that take-up thread tension lever is another name for thread-amount adjusting plate.

二十五. 中间导线钩 (图29) Frame thread eyelet (Fig.29)

中间导线钩的位置也关系到跳针现象的发生, 一般把下列位置作为基准 (图29)

棉 线#80~#50 中间导线钩刻度2-3 化纤线#80~#50 中间导线钩刻度1-2

棉 线#30~#20 中间导线钩刻度3-4 化纤线#30~#20 中间导线钩刻度2-3

The improper-positioning of the frame thread eyelet may be the cause of occurrence of skipping stitch.

The following locations are generally regarded as criteria (refer to Fig2)

Cotton thread #80~#50 Graduation marked on the frame thread eyelet 2-3

Cotton thread #80~#50 Graduation marked on the frame thread eyelet 3-4

Thread of chemical fibre #80~#50 Graduation marked on the frame thread eyelet 1-2

Thread of chemical fibre #80~#50 Graduation marked on the frame thread eyelet 2-3

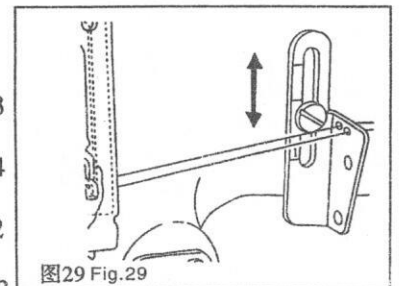


图29 Fig.29

二十六. 针板的调换 (图30) Replacement of throat plate (Fig.30)

The standard size of the throat plate in parts book, which is stipulated by the manufactory, is 1/4", equivalent to 6.4mm. (Fig.30)

The replacement of the following components is usually needle at the time when changing the gauge of double-row thread stitch.

1. Needle clamp
2. Hinged foot
3. Throat plate
4. Feed dog
5. Rear moving needle guard
6. Curler

The left and right loopers within the range of the sizes of 1/8" to 1/2" are interchangeable.

In addition to the aforesaid, the replacement of slide plate and cam cover shall be made when the width of thread plate is on the increase.

并列双针链缝机针迹间距出厂标准规格为1/4" (6.4mm)。 (图30)

改变缝线间距通常同时要更换:

- 1、针夹
- 2、活压脚
- 3、针
- 4、送料牙
- 5、摆动护针杆
- 6、卷边器左弯针和右弯针在1/8" ~1/2" 针板规格之内都通用。针板宽度大时, 除上述零件外还要调换推板和凸轮盖。

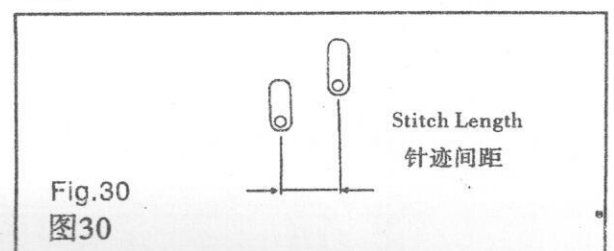


Fig.30
图30

二十七. 缝纫机的保养 Maintenance of the machine

为了使缝纫机保持良好的工作状态, 要做到以下事项:

(一) 每日必须检查的事项:

- 1、运转时, 油窗内有油在飞溅。
- 2、运转时, 一听到有异常声音, 即应停止缝纫作业, 并请修理工来检查。

(二) 每周一次检查部位:

- 1、拆下针板、推板、凸轮盖, 用刷子清洗送料牙槽中的灰尘。
- 2、把机头翻转, 去除油泵过滤网上的垃圾及油盘内的灰尘。
- 3、发现润滑油黑脏时, 只需旋下油盘的排油螺钉排空污油, 揩去沾在油盘和磁铁上的油污, 再紧固排油螺钉后, 注入新的润滑油。
- 4、油面必须高于最低线 (LOW)

The following shall be adhered in order to keep the machine in good working condition.

(1) Daily checking

I. The oil shall spray onto the oil sight when the machine is running.

II. Repairman shall be sent for when abnormal sound is heard during the operation of the machine.

(2) Locations to be checked once a week:

I. To make off throat plate, slide plate, and cam cover; to clean dust of the slotted feed dog with a brush.

II. To turn over the over the head to rid both the oil filter screen on the oil pump and the interior of the oil reservoir of oil stain and dust.

III. Loosen drain hole screw and take it off; drain all the dirty oil from the oil reservoir and recoil it.

IV. Oil level must be above the lowest oil-level-indicating line marked "Low"

V. The black powder, adhering to the magnet in the oil reservoir shall be wiped with sponge cloth.

二十八. 故障和措施 Common breakdowns and measures of trouble shooting

序号	事故内容	原因	对 象
1	断 线	1、缝线质量差 2、缝线太粗 (线比针槽粗) 3、机针过热熔断缝线 4、缝线张力太强 5、机针、弯针、针板、保针架过线部份损伤 6、线量未调节好	1、使用质量好的缝线 2、调换合适的缝线 3、使用硅油或降低转速 4、旋松夹线螺母 5、用油石磨光再抛光 6、调节线量调节板
2	跳 针	1、面线跳针	1、调整弯针勾取量 2、调整弯针与机针的间隙 3、调整机针同弯针的同步 4、根据缝线的情况调整线量调节板 5、调整中间导线钩的位置 6、检查机针安装是否正确 7、检查保针架的位置和同步是否正确 8、检查缝线是否穿正确
		2、底线跳针	1、按上述面线跳针1、2检查 2、检查底线凸轮的同步 3、稍微增强底线的张力 4、检查缝线穿得是否正确
		3、使用化纤线时的跳针	1、使用硅油 2、降低转速 3、使用化纤线用的机针
		4、使用合成纤维线时的跳针	1、降低转速 2、使用硅油

3	线迹不良	1、面线张力太弱 2、底线张力太弱 3、缝线太粗 4、中间导线钩的位置不够正确 5、挑线杆位置调节板位置不正确 6、针板	1、旋紧面线夹线螺母 2、旋紧底线夹线螺母 3、调换大号机针 4、调整中间导线钩的位置 5、调整线量调节板的位置 6、使用针孔大的针板
4	断针	1、机针弯 2、送料和机针不同步 3、压脚的安装有问題 4、保针架有问題 5、面线张力过强 6、机针太粗	1、调换机针 2、调整到同步 3、压脚孔、针板孔的中心与机针中心要一致 4、检查保针架的位置和同步 5、放松面线张力 6、使用适合於缝料的机针
5	起绉	1、缝线张力过强 2、底线打线凸轮不同步 3、各过线处光洁度有问題 4、压脚压力太强	1、降低缝线张力、特别是底线的张力 2、进行调节,使其同步 3、研磨各过线部件 4、旋松调压螺钉

No.	Breakdown	Cause	Measures to be taken
1	Thread breakage	1 Poor thread quality 2 Thread being too thick 3 Fusing thread due to high temperature of needle caused by machines operation at high speed 4 Tension being too higher 5 Breakage of needle, looper, throat plate, and needle guard at the location of thread guide. 6 Failure to adjust thread amount	1. Quality thread to be used. 2. Replacement to be made by an appropriate thread 3. Silicone oil to be loosened 4. The tension nut to be loosened 5. First grinding with oil stone and then polishing 6. Adjusting the thread amount adjusting plate
2	Skipping stitch	1. Skipping stitch of needle thread (leaking of two stitches due to the loopers failure to hook the needle thread) 2. Skipping stitch of bobbin thread (leaking of one stitch, needle failure to enter the looper eyelet) 3. Skipping stitch when thread of chemical fibre being in use 4. Skipping stitch when thread of polyester fibre being in use	1. Adjusting thread-hooking amount of looper. 2. Adjusting clearance between looper and needle. 3. The timing of needle in reference to looper. 4. Adjusting the thread-amount adjusting plate on thread amount changing conditions. 5. Adjusting the frame thread eyelet. 6. Checking whether the mounting position of the needle is proper or not. 7. To see if the location of needle guard is in an appropriate way and the timing of it is well regulated in relation to another. 8. To see if the needle thread threading is in a proper way. 1) Reference to the above cases 1 and 2, as to skipping stitch of the needle thread. 2) To see if the timing of bobbin thread cam has been well regulated. 3) Increasing tension of bobbin thread a bit higher. 4) To see if the threading of bobbin thread is in a correct way. 1) Using silicone oil. 2) Reducing speed 3) Using needle for thread of chemical fibre.
3	Twisted stitches	1. Needle thread tension being too low. 2. Bobbin thread tension being too low. 3. Sewing thread being too thick. 4. Improper position of the frame thread eyelet. 5. Improper position of thread take-up tension plate. 6. Throat plate	1. Tightening tension nut of needle thread. 2. Tightening tension nut of bobbin thread. 3. Needle of large size to be used. 4. Readjusting it to a proper position. 5. Readjusting its position in an appropriate way. 6. The eyelet of throat plate to be used being bigger than normal one.
4	Breakage of needle	1. Needle being bent. 2. The operation of feed dog being not well regulated in reference to the motion of needle. 3. Setting-up of the presser foot 4. The problem of the timing of needle guard remaining unsolved 5. Needle thread tension being too high. 6. Needle being too thick.	1. Needle to be replaced by another of proper size. 2. Readjusting the timing to feed dog in respect to the needle. 3. To make both the centre of the hole of the presser foot and the centre of the eyelet of the throat. 4. The positioning & the timing of the needle guard be taken into account. 5. Relaxing needle thread 6. Appropriate needle to be used.
5	Puckering	1. Thread tension being too high. 2. The problem of the timing of the bobbin thread cam for thread guiding failing to be solved. 3. The problem of surface finish arising from bobbin thread going through the parts on the thread guide. 4. The force on the presser foot being too great.	1. Decreasing thread tension, esp. Tension of bobbin thread. 2. Readjusting of the very cam said to solve the timing problem. 3. Surface finishing all the parts on the thread guide. 4. Turning counter-clockwise the pressure-regulating screw.

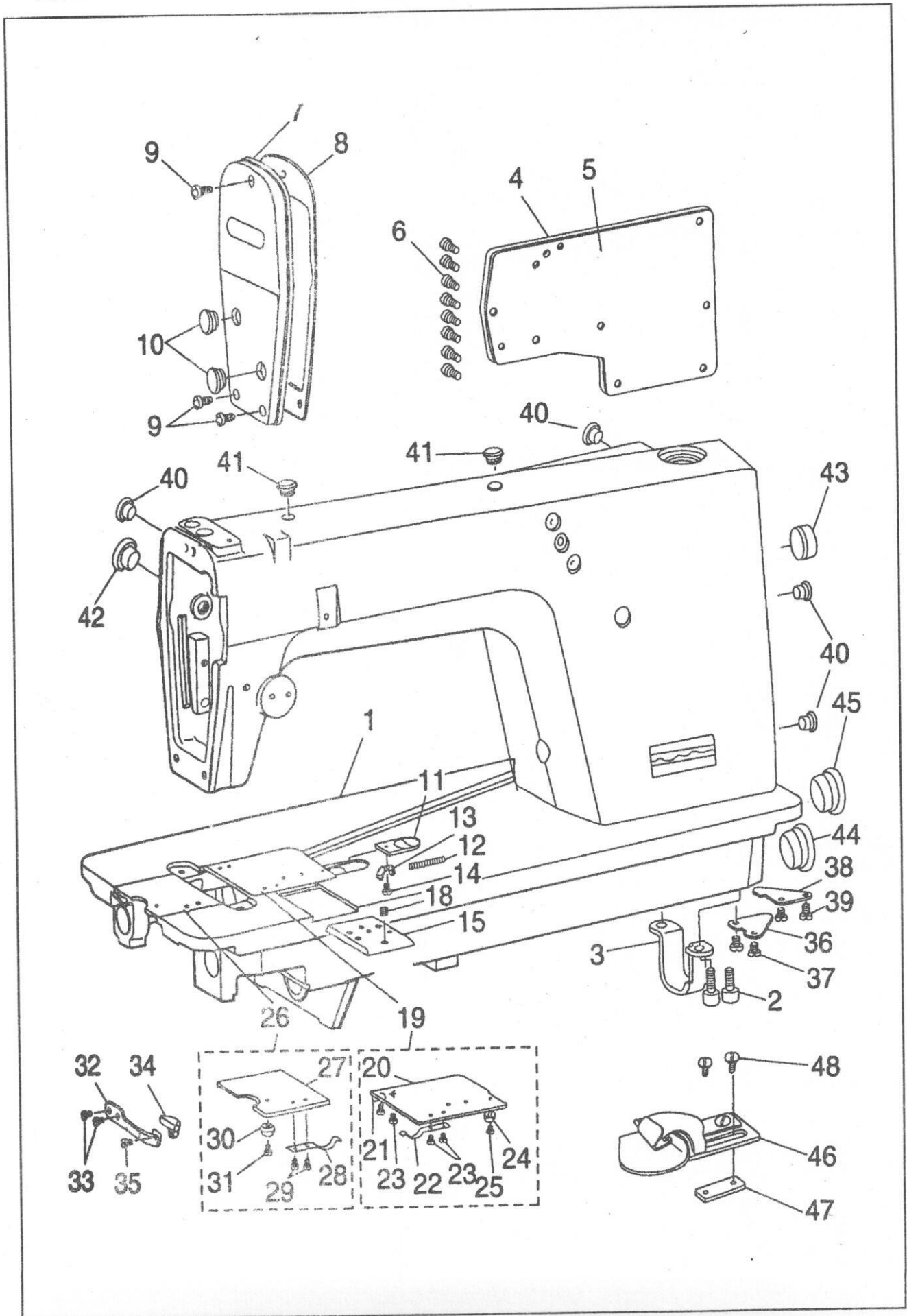
零件样本

Parts Book

1、机壳分组件 Arm Bed Components	13
2、上轴、针杆分组件 Main Shaft & Thread Bar Components	15
3、压料分组件 Presser Bar Components	17
4、送料分组件 Feed Mechanism Components	19
5、送料调节分组件 Feed Regulating Components	21
6、弯针勾线分组件 Looper Thread Retainer Complete	23
7、挑线、松线、夹线分组件 Thread Take-up, Tension, And Tension Releasing Assembly	25
8、润滑分组件 Lubrication Components	28
9、油盘、膝抬压脚分组件 Oil Reservoir & Knee Lifter Components	29
10、机头附件 Machine Head Accessories	30
11、四线团架分组件 Quadruple-thread Spool Stand Asm	31
12、高速单针链缝机 Model One-needle High Speed Chainstitcher	32
13、双针双列与双针单列零件变化表 List Of Parts Change	33
14、双针双列、双针单列附件一览表 List Throat Of & its Accessories	34
15、高速三针链缝机 Model Three-needle High Speed Chainstitcher	35

(本样本中图样、件号、名称、结构仅供参考,如有变动,以产品实物为准)

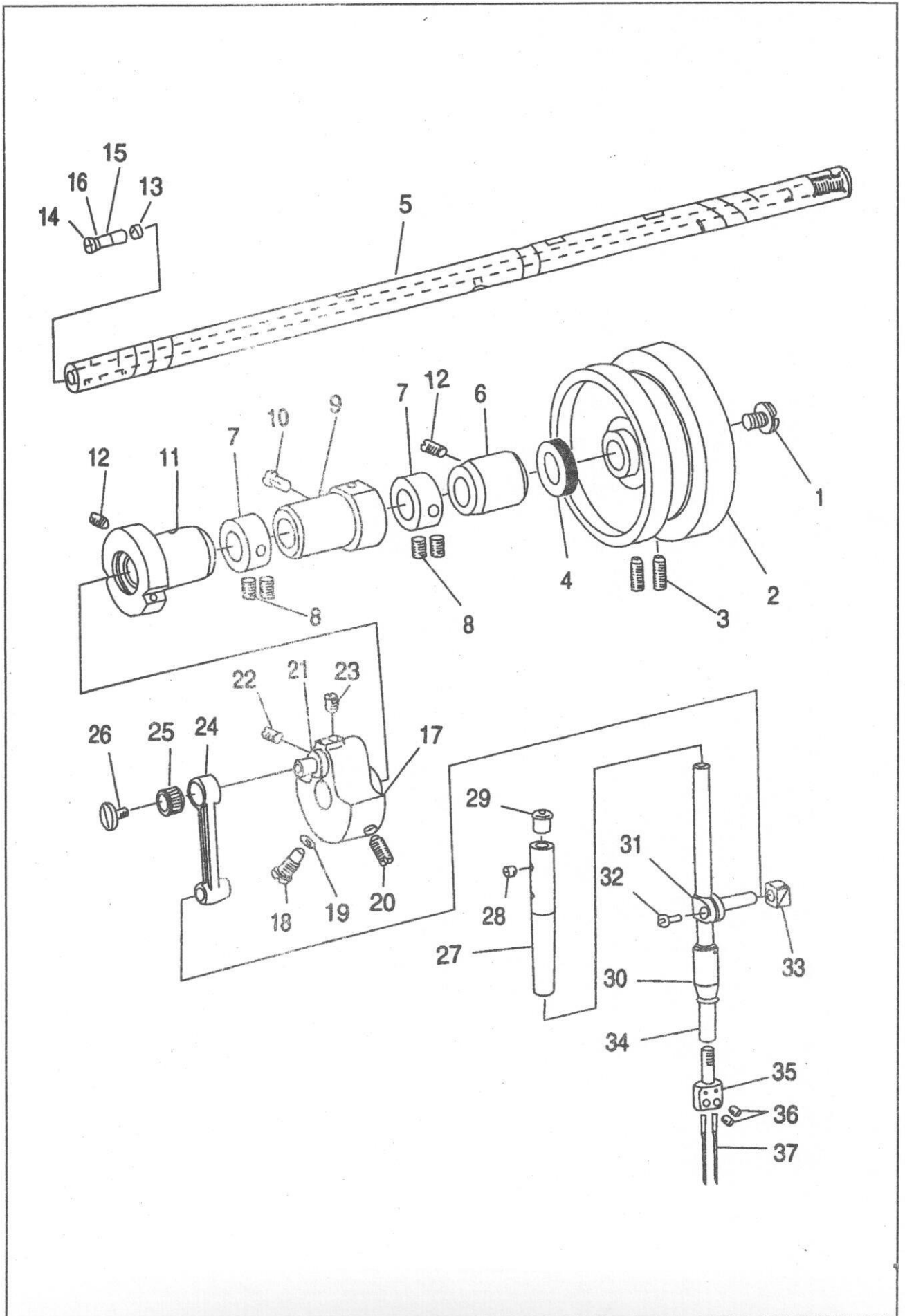
1. 机壳分组件 Arm bed components



1. 机壳分组件 Arm bed components

序号 Ref. No.	件号 Part No	名称 Description	数量 Arm. Req.
1	40-1-1	机壳部件 Arm Bed Complete	1
2	40-1-2	底板支承板螺钉 Bed Screw Stud	2
3	40-1-3	底板支承板 Bed Support	1
4	40-1-4	后窗板 Side Plate	1
5	40-1-5	后窗板垫 Gasket	1
6	40-1-6	后窗板螺钉 Side Plate Screw	8
7	40-1-7	面板 Face Plate Asm.	1
8	40-1-8	面板垫 Face Plate Gasket	1
9	40-1-9	面板螺钉 Screw	3
10	40-1-10	面板橡皮塞 Rubber Plug	2
11	40-1-11	凸轮盖压板 Cam Cover Latch	1
12	40-1-12	凸轮盖压板弹簧 Spring	1
13	40-1-13	凸轮盖压板弹簧座 Spring Suspension	1
14	40-1-14	凸轮盖压板座螺钉 Screw	1
15	40-1-15	附件安装板 Attachment Installing Plate	1
18	40-1-16	附件安装板定位螺钉 Screw	1
19	40-1-17	凸轮盖部件 Cam Cover Asm	(1)
20	40-1-18	凸轮盖 Cam Cover	1
21	40-1-19	凸轮盖托板 Cam Cover	1
22	40-1-20	凸轮盖弹簧 Spring	1
23	40-1-21	凸轮盖弹簧螺钉 Screw	4
24	40-1-22	凸轮盖导轮 Cam Cover Guide	1
25	40-1-23	凸轮盖导轮螺钉 Screw	1
26	40-1-24	推板部件 Bed Slide Asm.	(1)
27	40-1-25	推板 Bed Slide	1
28	40-1-26	推板簧 Spring	1
29	40-1-27	推板簧螺钉 Screw	2
30	40-1-28	推板导轮 Bed Slide Guide	1
31	40-1-29	推板导轮螺钉 Screw	1
32	40-1-30	推板锁簧 Bed Slide Lock Spring	1
33	40-1-31	推板锁簧螺钉 Screw	2
34	40-1-32	推板簧扳手 Latch	1
35	40-1-33	推板簧扳手螺钉 Screw	1
36	40-1-34	送料轴底板挡油板 Bed Oil Shield	1
37	40-1-35	底板挡油板螺钉 Screw	2
38	40-1-36	抬牙轴底板挡油板 Bed Oil Shield	1
39	40-1-37	底板挡油板螺钉 Screw	2
40	40-1-38	轴套定位螺孔塞 Rubber Plug	4
41	40-1-39	上轴套油线孔塞 Rubber Plug	2
42	40-1-40	针杆曲柄螺孔塞 Rubber Plug	1
43	40-1-41	送料针距调节器孔塞 Rubber Plug	1
44	40-1-42	抬牙轴孔塞 Rubber Plug	1
45	40-1-43	下轴孔塞 Rubber Plug	1
46	40-1-44	卷边器部件(1/4") Folder	1
47	40-1-45	卷边器垫块 Gasket	1
48	40-1-46	卷边器螺钉 Screw	2

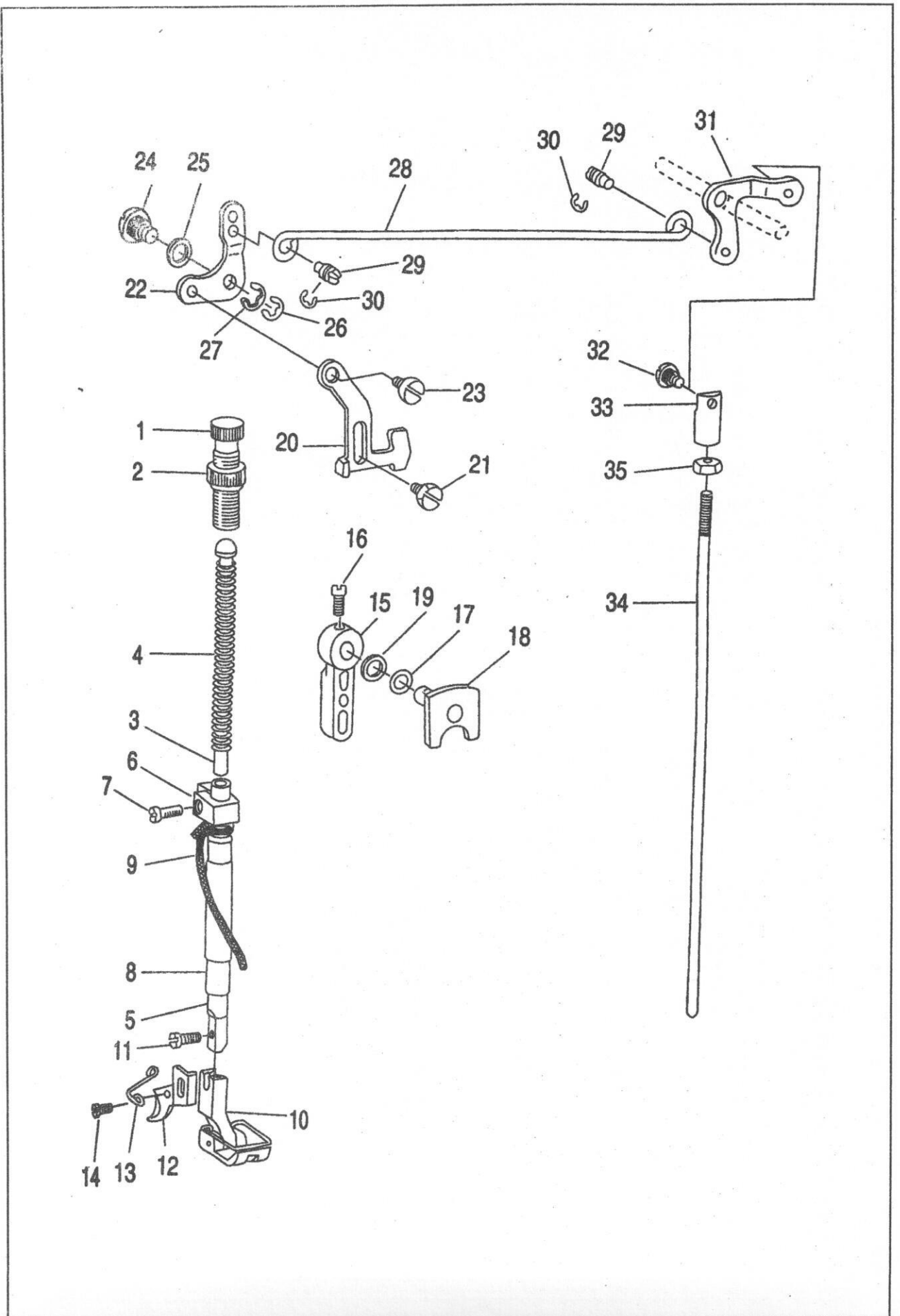
2. 上轴针杆组件 Main shaft & needle bar components



2. 上轴针杆分组件 Main shaft & needle bar components

序号 Ref. No.	件号 Part No	名称 Description	数量 Arm. Req.
1	40-2-1	上轴安全螺钉 End Screw	1
2	40-2-2	上轮 Hand Wheel	1
3	40-2-3	上轮螺钉 Screw	2
4	40-2-4	上轮油封 Oil Seal	1
5	40-2-5	上轴 Main Shaft	1
6	40-2-6	上轴后轴套部件 Main Shaft Bushing, Rear	1
7	40-2-7	上轴挡圈 Main Shaft Thrust Collar	2
8	40-2-8	上轴挡圈螺钉 Screw	4
9	40-2-9	上轴中轴套部件 Main Shaft Bushing Intermediate	1
10	40-2-10	中轴套螺钉 Screw	1
11	40-2-11	上轴前轴套部件 Main Shaft Bushing, Front	1
12	40-2-12	轴套螺钉 Screw	2
13	40-2-13	曲柄油量限制毡 Roller Felt	1
14	40-2-14	曲柄油量调节销 Crank Oil Adjusting Pin	1
15	40-2-15	曲柄油量调节销套 Rubber Bushing	1
16	40-2-16	曲柄油量调节销O形圈 O-Rubber Ring	1
17	40-2-17	针杆曲柄 Counterweight Asm.	1
18	40-2-18	针杆曲柄定位螺钉 Screw	1
19	40-2-19	定位螺钉O形圈 O-Rubber Ring	1
20	40-2-20	针杆曲柄紧固螺钉 Screw	1
21	40-2-21	针杆连杆销 Needle Crank	1
22	40-2-22	挑线曲柄定位螺钉 Screw	1
23	40-2-23	挑线曲柄螺钉 Screw	1
24	40-2-24	针杆连杆 Needle Bar Crank Rod	1
25	40-2-25	针杆连杆滚针轴承 Needle Rollar Bearing	1
26	40-2-26	针杆连杆左旋螺钉 Left Twist Screw	1
27	40-2-27	针杆上衬套 Needle Bar Bushing Upper	1
28	40-2-28	针杆上衬套螺钉 Screw	1
29	40-2-29	针杆上衬套孔塞 Rubber Plug	1
30	40-2-30	针杆下衬套 Needle Bar Bushing, Lower	1
31	40-2-31	针杆连接柱 Needle Bar Connection Asm.	1
32	40-2-32	针杆连接柱螺钉 Screw	1
33	40-2-33	针杆连接柱滑块 Crank Slide Block	1
34	40-2-34	针杆 Needle Bar	1
35	40-2-35	针夹(1/4") Needle Clamp (1/4")	1
36	40-2-36	支针螺钉 Screw	2
37	40-2-37	机针 Needle	2

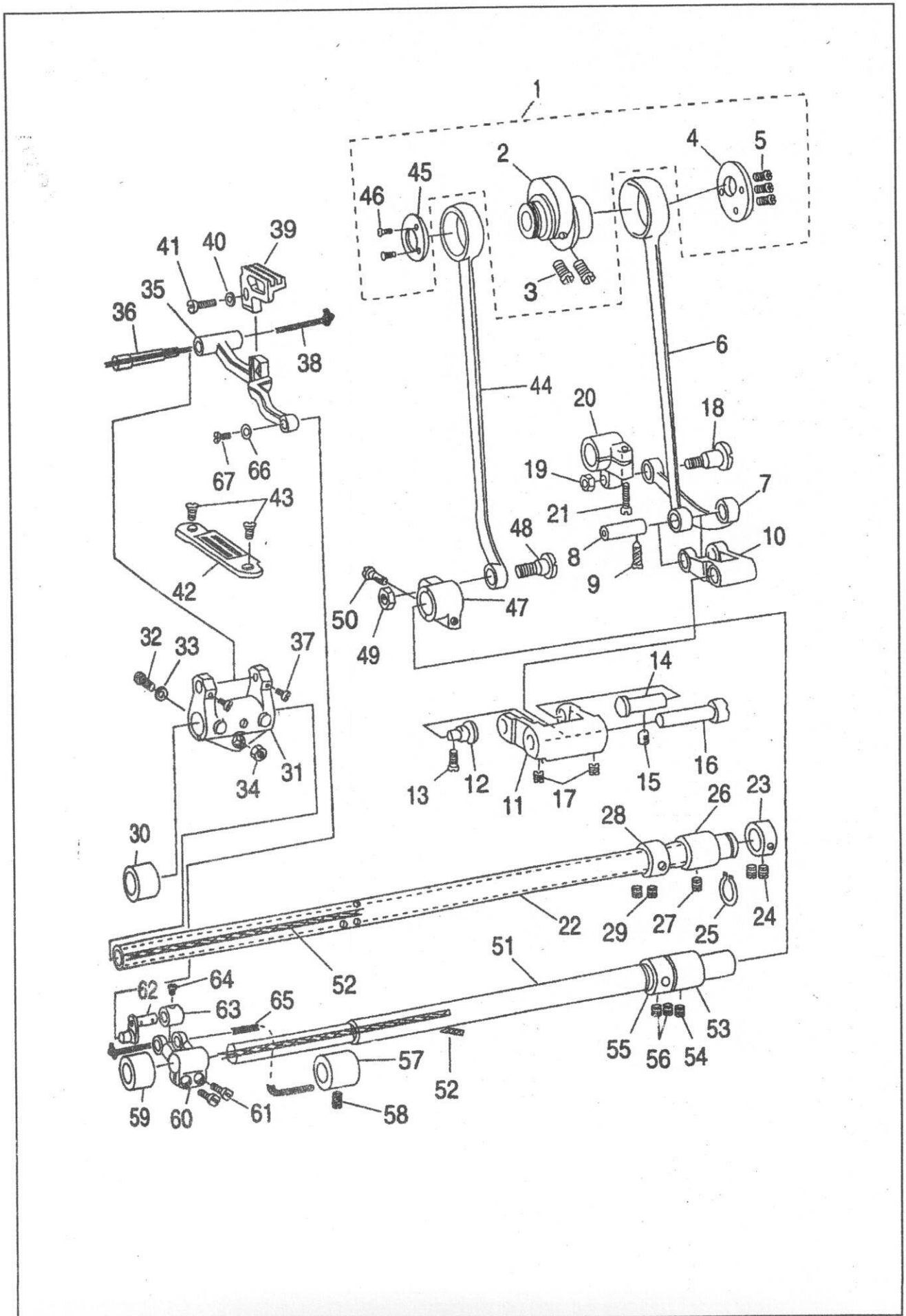
3. 压料分组件 Presser bar components



3. 压料分组件 Presser bar components

序号 Ref. No.	件号 Part No	名称 Description	数量 Arm. Req.
1	40-3-1	调压螺钉 Presser Spring Regulator	1
2	40-3-2	调压螺钉螺母 Nut	1
3	40-3-3	调压导杆 Presser Bar Guide Bar	1
4	40-3-4	调压簧 Presser Spring	1
5	40-3-5	压杆 Presser Bar	1
6	40-3-6	压杆导架 Presser Bar Guide Bracket Asm.	1
7	40-3-7	压杆导架螺钉 Screw	1
8	40-3-8	压杆衬套 Presser Bar Bushing, Lower	1
9	40-3-9	压杆油线 Oil Wick	1
10	40-3-10	压脚部件1/4" Presser Foot Asm.	1
11	40-3-11	压脚螺钉 Screw	1
12	40-3-12	切线刀 Thread Knife	1
13	40-3-13	切线刀导钩 Thread Knife Guide	1
14	40-3-14	切线刀导钩螺钉 Screw	1
15	40-3-15	压脚扳手 Hand Lifter	1
16	40-3-16	压脚扳手螺钉 Screw	1
17	40-3-17	压脚扳手垫圈 Washer	1
18	40-3-18	压脚提升凸轮 Hand Lifter Cam Asm.	1
19	40-3-19	压脚扳手轴O形圈 Rubber Ring	1
20	40-3-20	压脚升降板 Lifting Lever	1
21	40-3-21	升降板轴位螺钉 Hinge Screw	1
22	40-3-22	抬压脚前杠杆 Lifting Link For Lifting Lever	1
23	40-3-23	前杠杆轴位螺钉 Hinge Screw	1
24	40-3-24	前杠杆螺纹销 Hinge Pin	1
25	40-3-25	前杠杆螺纹销垫圈 Lifting Lever Gasket	1
26	40-3-26	前杠杆特制开口挡圈 Snap Ring	1
27	40-3-27	前杠杆开口挡圈 Snap Ring	1
28	40-3-28	抬压脚拉杆 Lifting Lever Connecting Rod	1
29	40-3-29	抬压脚拉杆螺钉 Screw	2
30	40-3-30	抬压脚拉杆开口挡圈 Snap Ring	2
31	40-3-31	抬压脚后杠杆 Lifting Lever Link Rear	1
32	40-3-32	后杠杆轴位螺钉 Hinge Screw	1
33	40-3-33	抬压脚顶杆接头 Swivel	1
34	40-3-34	抬压脚顶杆 Lifting Lever Connecting Rod, Vertical	1
35	40-3-35	抬压脚顶杆螺母 Nut	1

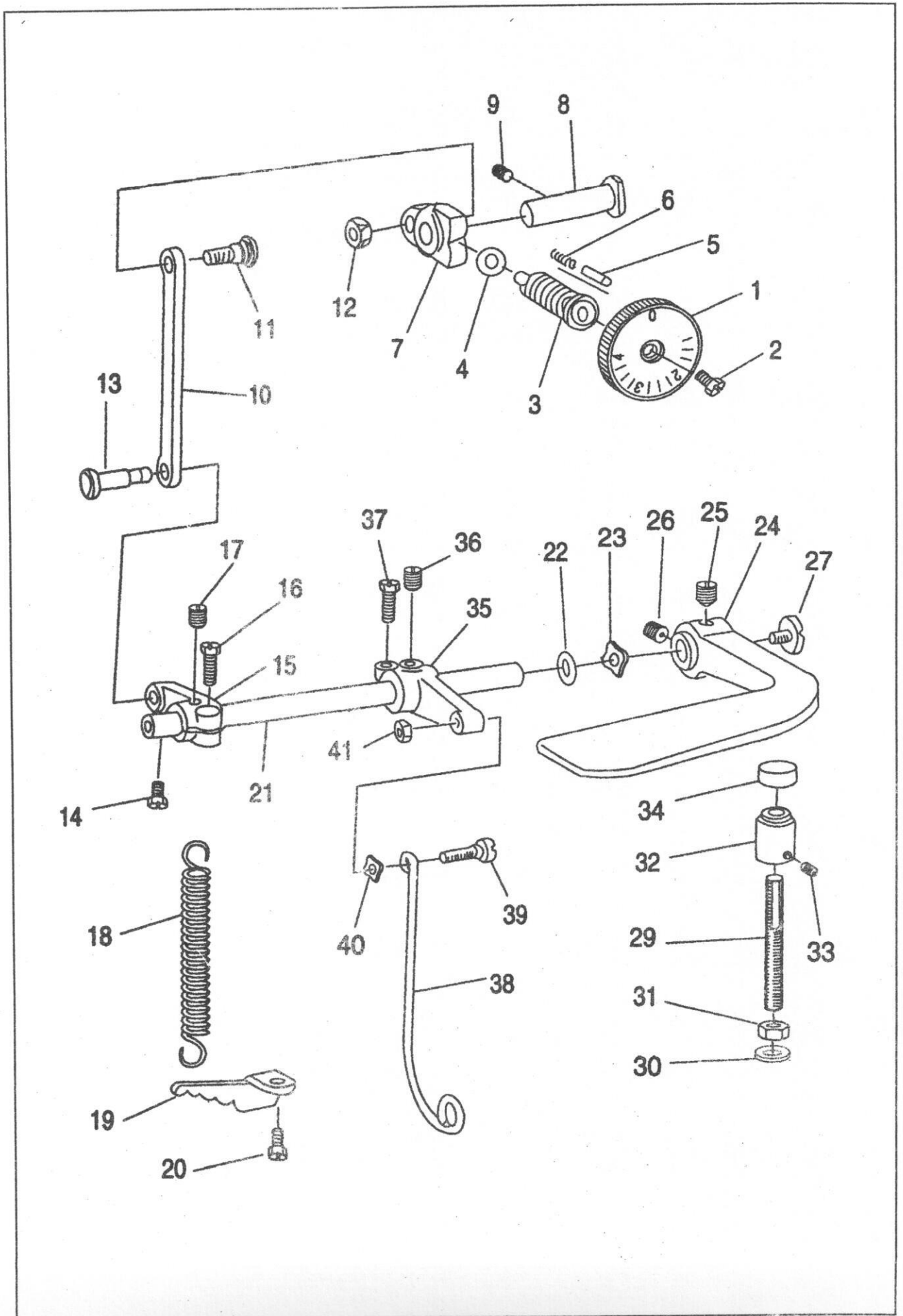
4. 送料分组件 Feed mechanism components



4. 送料分组件 Feed mechanism components

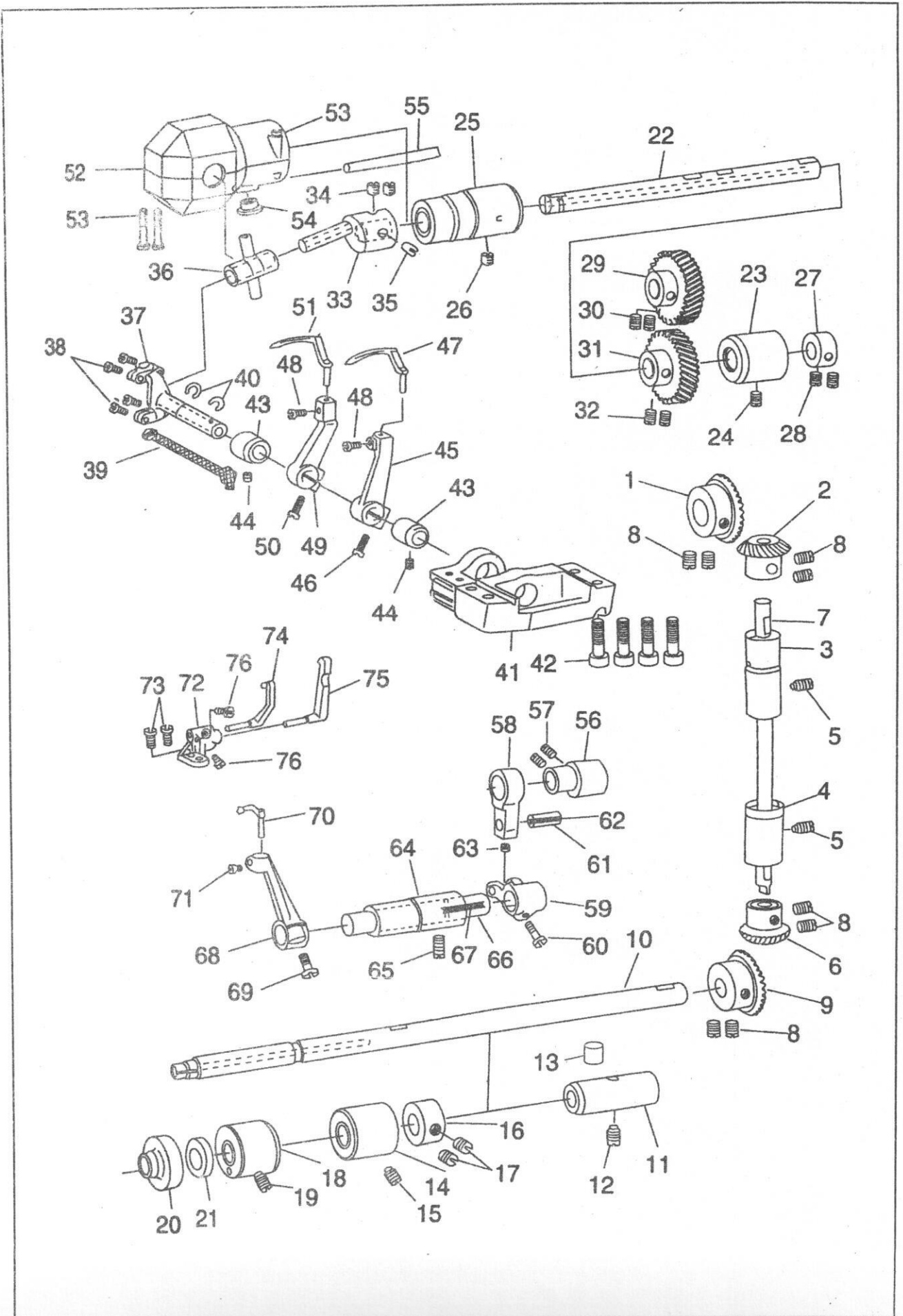
序号 Ref. No.	件号 Part No	名称 Description	数量 Arm. Req.	
1	40-4-1	送料偏心轮部件	Feed eccentric cam asm.	1
2	40-4-2	送料偏心轮	Feed eccentric cam	1
3	40-4-3	送料偏心轮螺钉	Screw	2
4	40-4-4	送料偏心轮盖板	Feed eccentric thrust washer	1
5	40-4-5	偏心轮盖板螺钉	Screw	3
6	40-4-6	送料大连杆	Feed rocker shaft connecting rod	1
7	40-4-7	送料小连杆	Connecting rod	1
8	40-4-8	送料连杆销	Connecting pin	1
9	40-4-9	送料连杆销螺钉	Screw	1
10	40-4-10	送料摆杆	Feed driving rocker asm.	1
11	40-4-11	送料摆杆座	Reed driving rocker	1
12	40-4-12	送料摆杆座左销	Hinge stud	1
13	40-4-13	送料摆杆座左销螺钉	Screw	1
14	40-4-14	送料摆杆座右销	Hinge pin	1
15	40-4-15	送料摆杆座右销螺钉	Screw	1
16	40-4-16	送料摆杆销	Hinge pin	1
17	40-4-17	送料摆杆销螺钉	Screw	2
18	40-4-18	送料曲柄轴位螺钉	Hinge screw	1
19	40-4-19	送料曲柄轴位螺母	Nut	1
20	40-4-20	送料曲柄	Feed rocker shaft crank	1
21	40-4-21	送料曲柄螺钉	Screw	1
22	40-4-22	送料轴薄挡圈	Feed rocket shaft	1
23	40-4-23	送料轴薄挡圈螺钉	Thrust collar	1
24	40-4-24	送料轴轴用挡圈	Screw	2
25	40-4-25	送料轴后轴套	Retaining ring	1
26	40-4-26	送料轴后轴套螺钉	Bushing rear	1
27	40-4-27	送料轴挡圈	Screw	1
28	40-4-28	送料轴挡圈螺钉	Thrust collar	1
29	40-4-29	送料轴前轴套	Screw	2
30	40-4-30	牙架座	Feed rocker shaft bushing, front	1
31	40-4-31	牙架座螺钉	Feed rocker	1
32	40-4-32	牙架座螺钉垫圈	Screw	1
33	40-4-33	牙架座螺钉螺母	Washer	1
34	40-4-34	牙架	Nut	1
35	40-4-35	牙架销	Feed bar	1
36	40-4-36	牙架销螺钉	Feed bar shaft	1
37	40-4-37	牙架销油线	Screw	2
38	40-4-38	送料牙1/4"	Oil wick	1
39	40-4-39	送料牙垫圈	Reed dog (1/4)	1
40	40-4-40	送料牙螺钉	Washer	1
41	40-4-41	针板1/4"	Screw	1
42	40-4-42	针板螺钉	Throat plate (1/4)	1
43	40-4-43	拾牙连杆	Screw	2
44	40-4-44	拾牙连杆凸轮盖	Feed driving shaft connecting rod	1
45	40-4-45	拾牙连杆凸轮盖螺钉	Feed driving eccentric thrust washer	1
46	40-4-46	拾牙后曲柄	Screw	2
47	40-4-47	拾牙连杆轴位螺钉	Feed driving shaft crank rear	1
48	40-4-48	拾牙连杆轴位螺母	Hinge screw	1
49	40-4-49	拾牙后曲柄紧固螺钉	Nut	1
50	40-4-50	拾牙轴	Screw	1
51	40-4-51	拾牙轴油线	Feed driving shaft	1
52	40-4-52	拾牙轴后轴套	Oil wick	2
53	40-4-53	拾牙轴后轴套螺钉	Bushing, rear	1
54	40-4-54	拾牙轴后轴套挡圈	Screw	1
55	40-4-55	后轴套挡圈螺钉	Thrust collar	1
56	40-4-56	拾牙轴中轴套	Screw	2
57	40-4-57	拾牙轴中轴套螺钉	Bushing, intermediate	1
58	40-4-58	拾牙轴前轴套	Screw	1
59	40-4-59	拾牙轴前曲柄	Feed rocker shaft bushing, front	1
60	40-4-60	拾牙轴前曲柄螺钉	Feed rocker shaft crank	1
61	40-4-61	牙架连杆	Screw	2
62	40-4-62	牙架连杆挡圈	Feed bar link	1
63	40-4-63	牙架连杆挡圈螺钉	Thrust collar	1
64	40-4-64	牙架连杆油线	Screw	1
65	40-4-65	牙架连杆锥孔垫圈	Oil wick	1
66	40-4-66	牙架连杆垫圈螺钉	Counter-sunk washer	1
67	40-4-67	针板5/32"	Screw	1
		针板3/16"		

5. 送料调节分组件 Feed regulating components



序号 Ref. No.	件号 Part No	名称 Description	数量 Arm. Req.
1	40-5-1	送料距旋钮部件 Stitch dial asm.	1
2	40-5-2	送料距旋钮螺钉 Screw	1
3	40-5-3	送料调节螺柱 Feed regulating screw	1
4	40-5-4	送料调节螺柱O形圈 O-Rubber ring	1
5	40-5-5	送料距锁合销 Stitch dial lock pin	1
6	40-5-6	送料距锁合销簧 Stitch dial lock spring	1
7	40-5-7	送料调节器 Feed regulator	1
8	40-5-8	送料调节器销 Hinge pin	1
9	40-5-9	送料调节器销螺钉 Screw	1
10	40-5-10	送料调节器连杆 Feed regulator connecting rod	1
11	40-5-11	调节器连杆轴位螺钉 Hinge screw	1
12	40-5-12	调节器连杆轴位螺母 Nut	1
13	40-5-13	拉簧调节曲柄销 Tension spring suspension stud	1
14	40-5-14	拉簧调节曲柄销螺钉 Screw	1
15	40-5-15	拉簧调节曲柄 Tension spring suspension crank	1
16	40-5-16	调节曲柄紧固螺钉 Clamp screw	1
17	40-5-17	调节曲柄定位螺钉 Screw	1
18	40-5-18	倒送料轴拉簧 Tension spring	1
19	40-5-19	拉簧固定板 Suspension bracket	1
20	40-5-20	拉簧固定板螺钉 Screw	1
21	40-5-21	倒送料轴 Reverse feed control lever shaft	1
22	40-5-22	倒送料轴O形圈 Rubber ring, large	1
23	40-5-23	倒送料轴弹性垫圈 Waved washer	1
24	40-5-24	倒送料扳手 Reverse feed control lever	1
25	40-5-25	倒送料扳手定位螺钉 Screw	1
26	40-5-26	倒送料扳手螺钉 Screw	1
27	40-5-27	倒送料轴端螺钉 End screw	1
29	40-5-28	倒送料挡块螺杆 Screw	1
30	40-5-29	挡块螺杆垫圈 Washer	1
31	40-5-30	挡块螺杆螺母 Nut	1
32	40-5-31	倒送料挡块 Lever stopper	1
33	40-5-32	倒送料挡块螺钉 Screw	1
34	40-5-33	倒送料挡块橡胶垫 Rubber cushion	1
35	40-5-34	倒送料曲柄 Control lever crank, rear	1
36	40-5-35	倒送料曲柄定位螺钉 Screw	1
37	40-5-36	倒送料曲柄螺钉 Screw	1
38	40-5-37	倒送料连杆 Feed driving rocker arm connecting	1
39	40-5-38	倒送料连杆轴位螺钉 Screw	1
40	40-5-39	倒送料连杆轴位垫圈 Washer	1
41	40-5-40	倒送料连杆轴位螺母 Nut	1

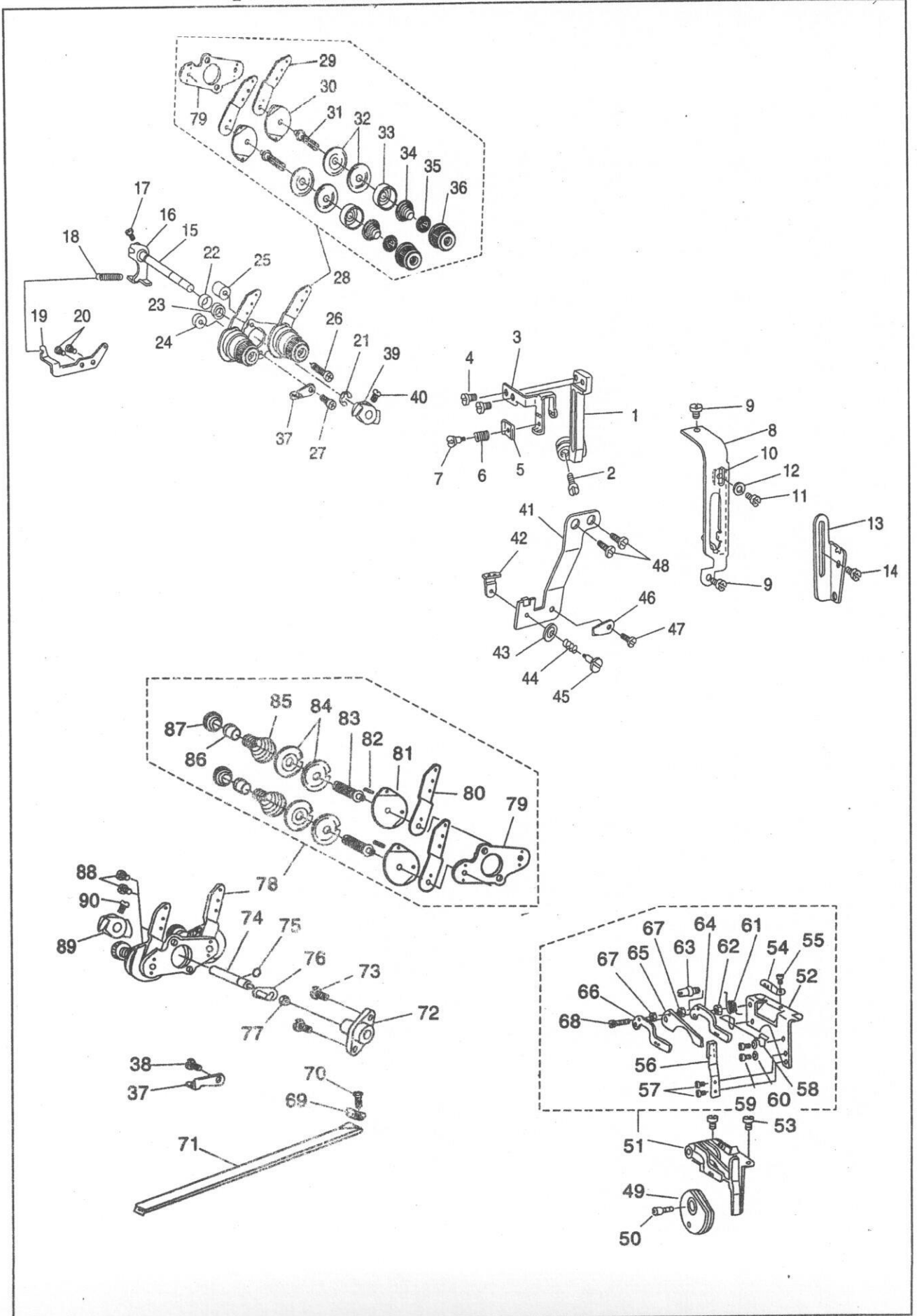
6. 弯针勾线分组件 Looper thread retainer components



序号 Ref. No.	件号 Part No	名称 Description	数量 Arm. Req.
1	40-6-1	上轴伞齿轮	1
2	40-6-2	竖轴上伞齿轮	1
3	40-6-3	竖轴上轴套	1
4	40-6-4	竖轴下轴套部件	1
5	40-6-5	竖轴轴套螺钉	2
6	40-6-6	竖轴下伞齿轮	1
7	40-6-7	竖轴	1
8	40-6-8	伞齿轮螺钉	8
9	40-6-9	下轴伞齿轮	1
10	40-6-10	下轴	1
11	40-6-11	下轴后轴套	1
12	40-6-12	下轴后轴套螺钉	1
13	40-6-13	下轴后轴套油毡	1
14	40-6-14	下轴中轴套部件	1
15	40-6-15	下轴中轴套螺钉	1
16	40-6-16	下轴挡圈	1
17	40-6-17	下轴挡圈螺钉	2
18	40-6-18	下轴轴套部件	1
19	40-6-19	下轴轴套螺钉	1
20	40-6-20	下轴前轴套油封套	1
21	40-6-21	下轴前轴套油封	1
22	40-6-22	弯针轴	1
23	40-6-23	弯针轴后轴套部件	1
24	40-6-24	弯针轴后轴套螺钉	1
25	40-6-25	弯针轴前轴套部件	1
26	40-6-26	弯针轴前轴套螺钉	1
27	40-6-27	弯针轴挡圈	1
28	40-6-28	弯针轴挡圈螺钉	2
29	40-6-29	主动弯针齿轮	1
30	40-6-30	主动弯针齿轮螺钉	2
31	40-6-31	被动弯针齿轮	1
32	40-6-32	被动弯针齿轮螺钉	2
33	40-6-33	弯针曲柄	1
34	40-6-34	弯针曲柄螺钉	2
35	40-6-35	弯针曲柄调节螺钉	1
36	40-6-36	弯针十字接头部件	1
37	40-6-37	弯针摆轴部件	1
38	40-6-38	弯针摆轴盖螺钉	4
39	40-6-39	弯针摆轴油线	1
40	40-6-40	弯针摆轴挡圈	2
41	40-6-41	弯针架座	1
42	40-6-42	弯针架座螺钉	4
43	40-6-43	弯针摆轴轴套	2
44	40-6-44	弯针摆轴轴套螺钉	2
45	40-6-45	左弯针曲柄	1
46	40-6-46	左弯针曲柄螺钉	1
47	40-6-47	左弯针	1
48	40-6-48	弯针螺钉	2
49	40-6-49	右弯针曲柄	1
50	40-6-50	右弯针曲柄螺钉	1
51	40-6-51	右弯针	1
52	40-6-52	弯针曲柄罩壳部件	1
53	40-6-53	曲柄罩壳螺钉	3
54	40-6-54	曲柄罩壳孔塞	1
55	40-6-55	曲柄罩壳排油管	1
56	40-6-56	护针凸轮	1
57	40-6-57	护针凸轮螺钉	2
58	40-6-58	护针连杆	1
59	40-6-59	护针叉形曲柄	1
60	40-6-60	护针叉形曲柄螺钉	1
61	40-6-61	护针曲柄销	1
62	40-6-62	护针曲柄销油线	1
63	40-6-63	护针曲柄销螺钉	1
64	40-6-64	护针轴套	1
65	40-6-65	护针轴套螺钉	1
66	40-6-66	护针轴	1
67	40-6-67	护针轴油线	1
68	40-6-68	护针曲柄	1
69	40-6-69	护针曲柄螺钉	1
70	40-6-70	摆动护针(1/4")	1
71	40-6-71	摆动护针杆螺钉	1
72	40-6-72	护针杆座	1
73	40-6-73	护针杆座螺钉	2
74	40-6-74	左固定护针杆	1
75	40-6-75	右固定护针杆	1
76	40-6-76	左右固定护针杆螺钉	2

7. 挑线、松线、夹线分组件

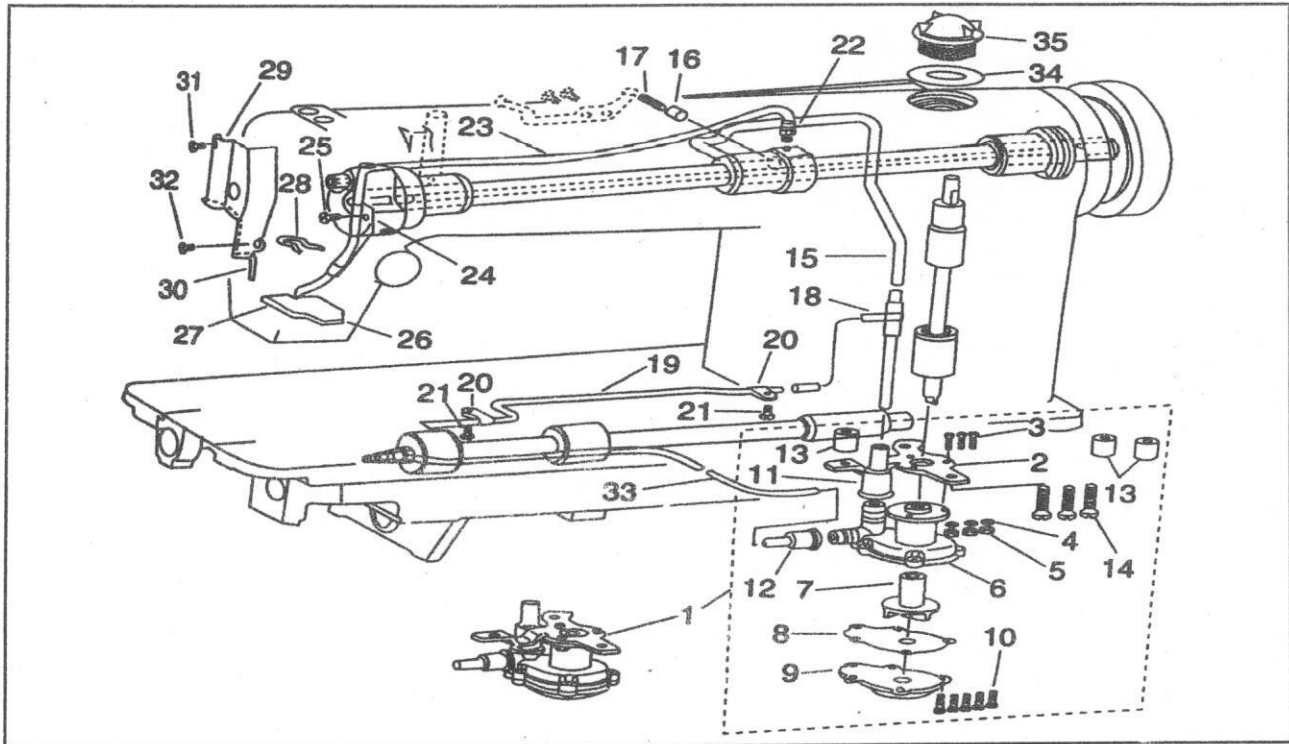
Thread take-up, tension, and tension releasing assembly complete



序号 Ref. No.	件号 Part No	名称 Description	数量 Arm. Req.
1	40-7-1	挑线连杆 Thread take-up lever	1
2	40-7-2	挑线连杆螺钉 Screw	1
3	40-7-3	挑线杆 Thread take-up	1
4	40-7-4	挑线杆紧固螺钉 Screw	2
5	40-7-5	挑线杆夹线板 Tension plate	1
6	40-7-6	挑线杆夹线簧 Tension spring	1
7	40-7-7	挑线杆夹线板轴螺钉 Screw	1
8	40-7-8	挑线杆护罩 Thread take-up lever guard	1
9	40-7-9	挑线杆护罩螺钉 Screw	2
10	40-7-10	线量调节板 Take-up thread tension lever	1
11	40-7-11	线量调节板螺钉 Screw	1
12	40-7-12	调节板螺钉垫圈 Washer	1
13	40-7-13	中间导线钩 Frame thread eyelet	1
14	40-7-14	中间导线钩螺钉 Screw	1
15	40-7-15	松线轴 Tension release shaft	1
16	40-7-16	面线松线曲柄部件 Tension release arm asm.	1
17	40-7-17	面线松线曲柄螺钉 Screw	1
18	40-7-18	抬压脚后杠杆弹簧 Spring	1
19	40-7-19	后杠杆弹簧固定板 Suspension bracket	1
20	40-7-20	后杠杆弹簧固定板螺钉 Screw	2
21	40-7-21	松线轴挡圈 Snap ring	1
22	40-7-22	松线轴油封 Oil seal ring	1
23	40-7-23	松线轴环 Tension release shaft spacer	1
24	40-7-24	夹线器下安装垫 Spacer (A) for installing plate	1
25	40-7-25	夹线器上安装垫 Spacer (B) for installing plate	1
26	40-7-26	夹线器上安装垫螺钉 Screw	1
27	40-7-27	夹线器下安装垫螺钉 Screw	1
28	40-7-28	面线夹线器部件 Needle thread tension asm.	(1)
29	40-7-29	面线单面导线板 Needle thread tension guide plate	2
30	40-7-30	面线双面导线板 Tension thread guide	2
31	40-7-31	夹线螺钉 Looper thread tension post	2
32	40-7-32	面线夹线板 Tension disc	4
33	40-7-33	面线松线座 Tension disc presser tube	2
34	40-7-34	面线夹线簧 Tension spring	2
35	40-7-35	面线止动板 Tension disc stopper	2
36	40-7-36	面线夹线螺母部件 Tension nut	2
37	40-7-37	导线钩 Frame thread guide	2
38	40-7-38	导线钩螺钉 Screw	1
39	40-7-39	面线松线爪 Tension release latch	1
40	40-7-40	面线松线爪螺钉 Screw	1
41	40-7-41	过线板架 Tension controller installing plate	1
42	40-7-42	过线板 Take-up thread guide	1
43	40-7-43	过线夹线板 Attachment installing plate	1
44	40-7-44	过线夹线簧 Take-up thread tension spring	1
45	40-7-45	过线夹线螺钉 Take-up thread tension port	1

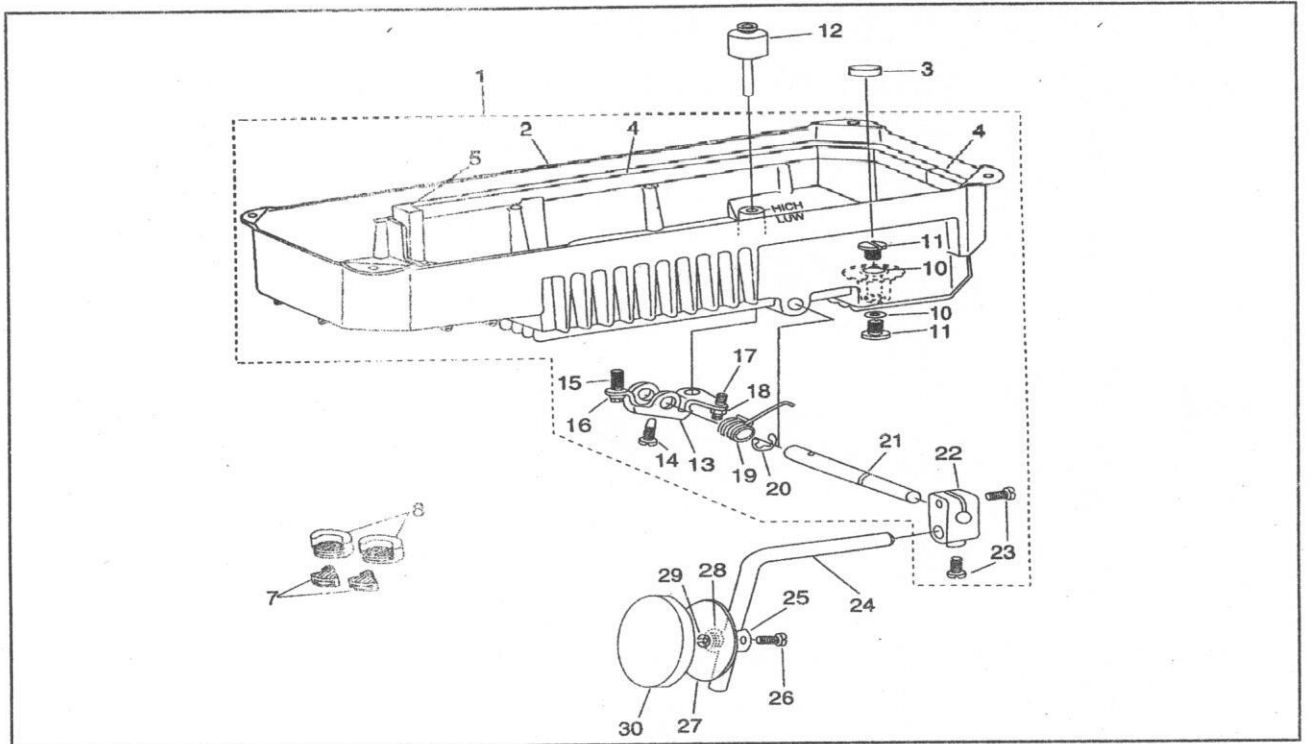
序号 Ref. No.	件号 Part No	名称 Description	数量 Arm. Req.	
46	40-7-46	松线板	Thread tension release guide latch	1
47	40-7-47	松线板螺钉	Screw	1
48	40-7-48	过线板螺钉	Screw	2
49	40-7-49	底线打线凸轮	Looper thread take-up cam	1
50	40-7-50	底线打线凸轮定位螺钉	Screw	1
51	40-7-51	凸轮导线钩部件	Looper thread guide asm.	1
52	40-7-52	凸轮导线架	Thread guide plate	1
53	40-7-53	凸轮导线架螺钉	Screw	2
54	40-7-54	底线双线导线钩	Looper thread guide	1
55	40-7-55	底线双线导线钩螺钉	Screw	1
56	40-7-56	底线导线止动簧	Thread guide stopper spring	1
57	40-7-57	底线导线止动簧螺钉	Screw	2
58	40-7-58	底线脱线钢丝	Cast-off wire	1
59	40-7-59	底线脱线钢丝螺钉	Screw	2
60	40-7-60	底线脱线钢丝螺钉垫圈	Washer	2
61	40-7-61	底线导线簧	Thread guide spring	1
62	40-7-62	凸轮过线螺钉螺母	Nut	1
63	40-7-63	凸轮过线螺钉	Thread guide stud	1
64	40-7-64	凸轮导线钩(右)	Looper thread guide, right	1
65	40-7-65	凸轮脱线爪	Cast-off plate	1
66	40-7-66	凸轮导线钩(左)	Looper thread guide, left	1
67	40-7-67	凸轮导线环	Collar	2
68	40-7-68	凸轮导线钩螺钉	Screw	1
69	40-7-69	底线导线钩	Looper thread guide	1
70	40-7-70	底线导线钩螺钉	Screw	1
71	40-7-71	底线导线管	Looper thread guide tube	1
72	40-7-72	松线轴套	Tension release shaft bushing	1
73	40-7-73	松线轴套螺钉	Screw	2
74	40-7-74	底线松线轴	Looper thread release shaft	1
75	40-7-75	底线松线轴O型圈	Rubber ring	1
76	40-7-76	底线松线轴曲柄部件	Tension release arm asm.	1
77	40-7-77	底线松线轴螺母	Nut	1
78	40-7-78	底线夹线器部件	Lower thread tension asm.	(1)
79	40-7-79	夹线器安装板	Tension installing plate	2
80	40-7-80	底线单面导线板	Looper thread tension control plate	2
81	40-7-81	底线双面导线板	Thread guide	2
82	40-7-82	底线夹线板止动销	Spring pin	2
83	40-7-83	夹线螺钉	Looper thread tension post	2
84	40-7-84	底线夹线板	Tension disc	4
85	40-7-85	底线夹线簧	Looper thread tension spring	2
86	40-7-86	底线夹线止转圈	Tension spring bushing	2
87	40-7-87	底线夹线螺母	Tension post nut	2
88	40-7-88	夹线器安装板螺钉	Screw	2
89	40-7-89	底线松线爪	Looper thread release latch	1
90	40-7-90	底线松线爪螺钉	Screw	1

8. 润滑分组件 Lubrication



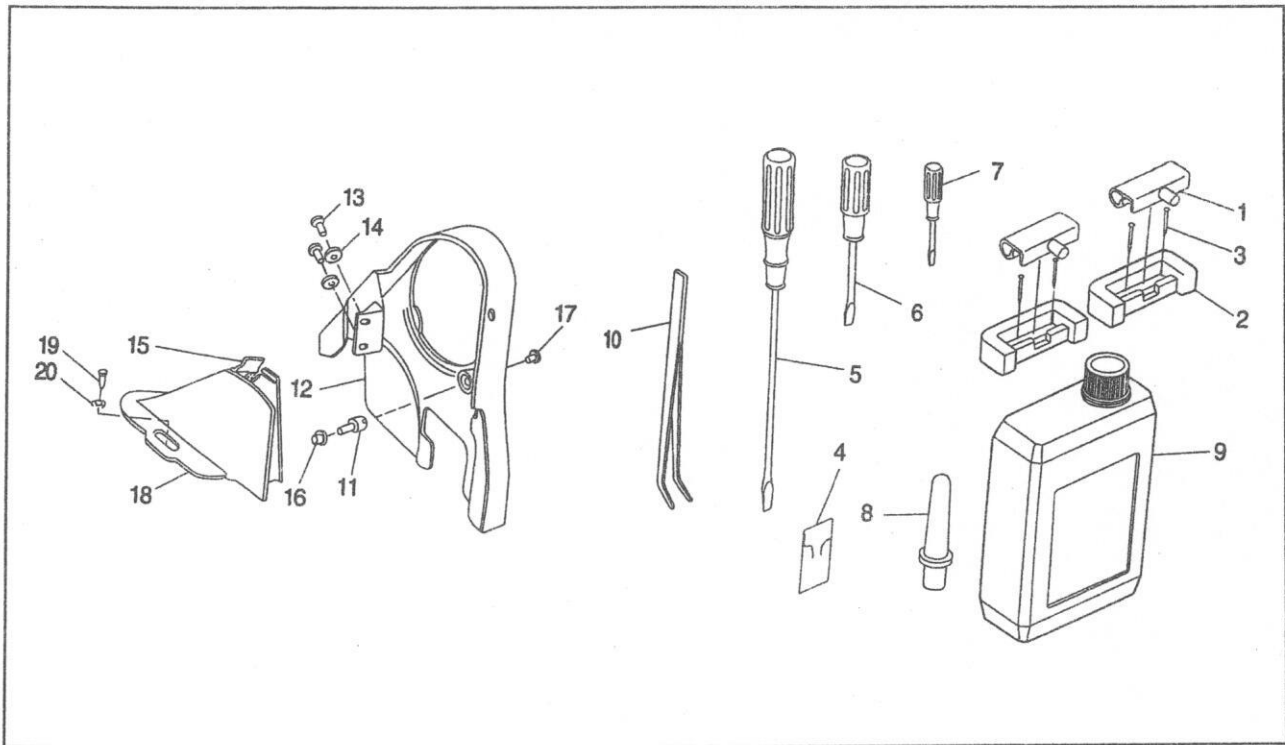
序号 Ref. No.	件号 Part No	名称 Description	数量 Arm. Req.
1	40-8-1	油泵部件 Lubricating oil pump asm.	(1)
2	40-8-2	油泵安装板 Oil pump installing base	1
3	40-8-3	油泵安装螺钉 Screw	3
4	40-8-4	油泵安装垫圈 Washer	3
5	40-8-5	油泵安装螺母 Nut	3
6	40-8-6	油泵体 Lubricating oil	1
7	40-8-7	油泵叶轮 Oil pump impeller	1
8	40-8-8	油泵叶轮托板 Oil pump impeller cover	1
9	40-8-9	油泵盖部件 Lubricating oil pump cover	1
10	40-8-10	油泵盖螺钉 Screw	5
11	40-8-11	上轴供油管接头 Rubber joint	1
12	40-8-12	下轴供油管接头 Rubber joint	1
13	40-8-13	油泵垫圈 Collar	3
14	40-8-14	油泵螺钉 Screw	3
15	40-8-15	上轴供油管 Main shaft oil tube	1
16	40-8-16	回油泵柱塞 Oil return pump plunger	1
17	40-8-17	柱塞簧 Plunger spring	1
18	40-8-18	齿轮供油管橡皮接头 Oil sight window base	1
19	40-8-19	齿轮供油管 Gear oil pipe	1
20	40-8-20	齿轮供油管夹 Holder	2
21	40-8-21	齿轮供油管夹螺钉 Screw	2
22	40-8-22	面部回油管连接螺钉 Connecting screw	1
23	40-8-23	回油管 Oil return tube asm.	1
24	40-8-24	回油管夹 Oil return tube holder	1
25	40-8-25	回油管夹螺钉 Screw	1
26	40-8-26	回油除尘毡 Oil felt presser	1
27	40-8-27	回油毡 Oil felt	1
28	40-8-28	回油毡夹 Oil felt presser	1
29	40-8-29	面部挡油板 Arm oil shield	1
30	40-8-30	面部挡油板油线 Oil wick	1
31	40-8-31	面部挡油板上螺钉 Screw	1
32	40-8-32	面部挡油板下螺钉 Screw	1
33	40-8-33	下轴供油管 Oil tube	1
34	40-8-34	油窗O形圈 O-Rubber ring	1
35	40-8-35	油窗 Oil sight window	1

9. 油盘、膝抬压脚分组件 Oil reservoir & knee lifter components



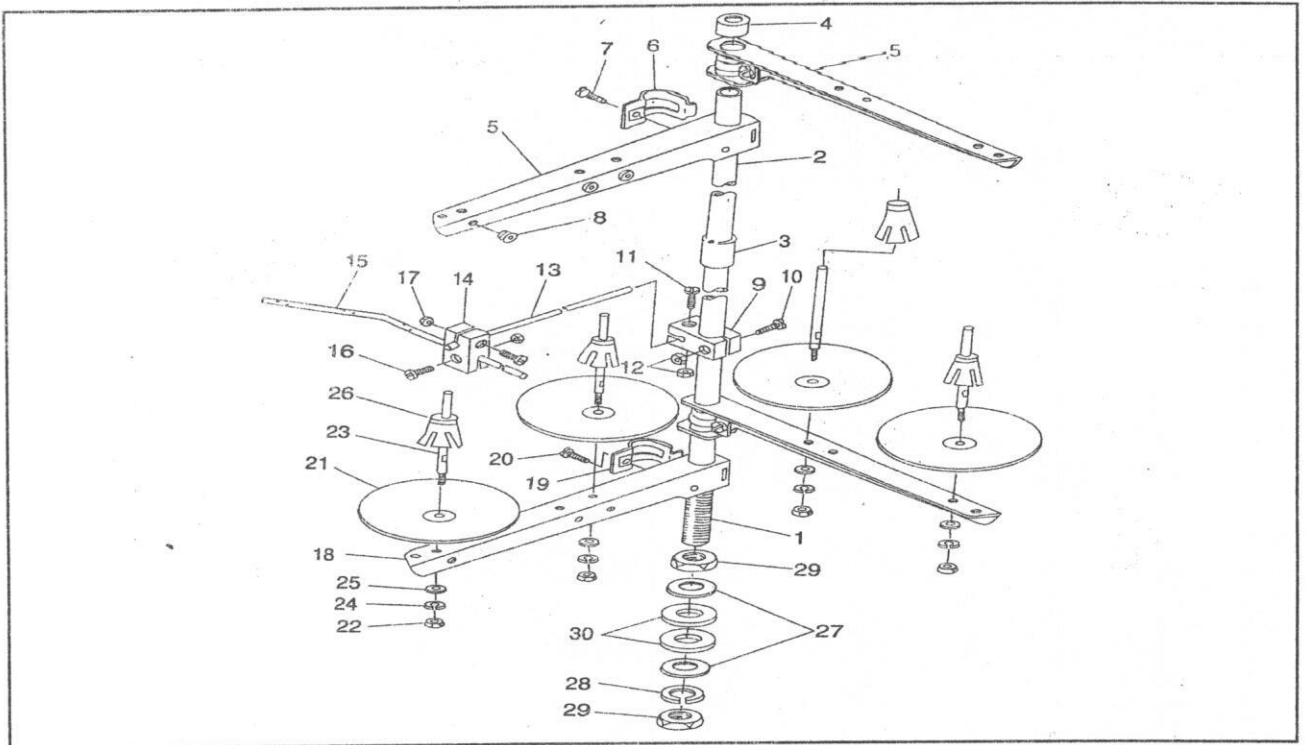
序号 Ref. No.	件号 Part No	名称 Description	数量 Arm. Req.
1	40-9-1	油盘部件 Oil reservoir asm.	(1)
2	40-9-2	油盘 Oil reservoir	1
3	40-9-3	油盘磁铁 Oil reservoir magnet	1
4	40-9-4	油盘侧面垫 Gasket	2
5	40-9-5	油盘端面垫 Gasket	1
7	40-9-6	油盘座垫 Oil reservoir felt cushion	2
8	40-9-7	油盘支座 Oil reservoir rubber cushion	2
10	40-9-8	排油螺钉O形圈 Oil drain cap gasket	2
11	40-9-9	排油螺钉 Oil drain screw	2
12	40-9-10	抬压脚顶销 Knee press lifter rod	1
13	40-9-11	抬压脚双向曲柄 Lifting	1
14	40-9-12	双向曲柄螺钉 Positioning screw	1
15	40-9-13	双向曲柄限位螺钉 Positioning screw	1
16	40-9-14	双向曲柄限位螺母 Nut	1
17	40-9-15	双向曲柄调节螺钉 Positioning screw	1
18	40-9-16	双向曲柄调节螺母 Nut	1
19	40-9-17	双向曲柄扭簧 Spring	1
20	40-9-18	抬压脚轴开口挡圈 Thrust ring	1
21	40-9-19	抬压脚轴 Knee press rod	1
22	40-9-20	抬压脚操纵杆节头 Bearing bracket	1
23	40-9-21	操纵杆节头螺钉 Clamp screw	2
24	40-9-22	操纵杆 Knee lifter plate rod	1
25	40-9-23	操纵板节头 Knee press plate cover joint	1
26	40-9-24	操纵板节头螺钉 Screw	1
27	40-9-25	操纵板 Knee press plate	1
28	40-9-26	操纵板簧 Knee press plate spring	1
29	40-9-27	操纵板螺钉 Screw	1
30	40-9-28	操纵板软垫 Knee press plate cover	1

10. 机头附件 Machine head accessories



序号 Ref. No.	件号 Part No	名称 Description	数量 Arm. Req.
1	40-10-1	机头连接钩部件 Machine hinge plate asm.	2
2	40-10-2	机头连接钩座 Machine hinge plate	2
3	40-10-3	机头连接钩座钉 Nail	4
4	40-10-4	机针 Needle	1包
5	40-10-5	螺丝刀(大) Screw driver (L)	1
6	40-10-6	螺丝刀(中) Screw driver (M)	1
7	40-10-7	螺丝刀(小) Screw driver (S)	1
8	40-10-8	机头支柱 Machine rest pin	1
9	40-10-9	油箱部件 Lubricating unit case asm.	1
10	40-10-10	镊子 Tweezer	1
11	40-10-11	罩壳支柱 Belt cover support stud	1
12	40-10-12	上轮前罩壳 Belt-cover A	1
13	40-10-13	罩壳螺钉 Screw	2
14	40-10-14	罩壳螺钉垫圈 Washer	2
15	40-10-15	后罩壳盖 Belt-cover b cover asm.	1
16	40-10-16	罩壳支柱螺母 Nut	1
17	40-10-17	前罩壳紧固螺钉 Screw	1
18	40-10-18	上轮后罩壳 Belt-cover B	1
19	40-10-19	传动带罩壳木螺钉 Driving belt cover wood screw	2
20	40-10-20	罩壳木螺钉垫圈 Wood screw washer	2

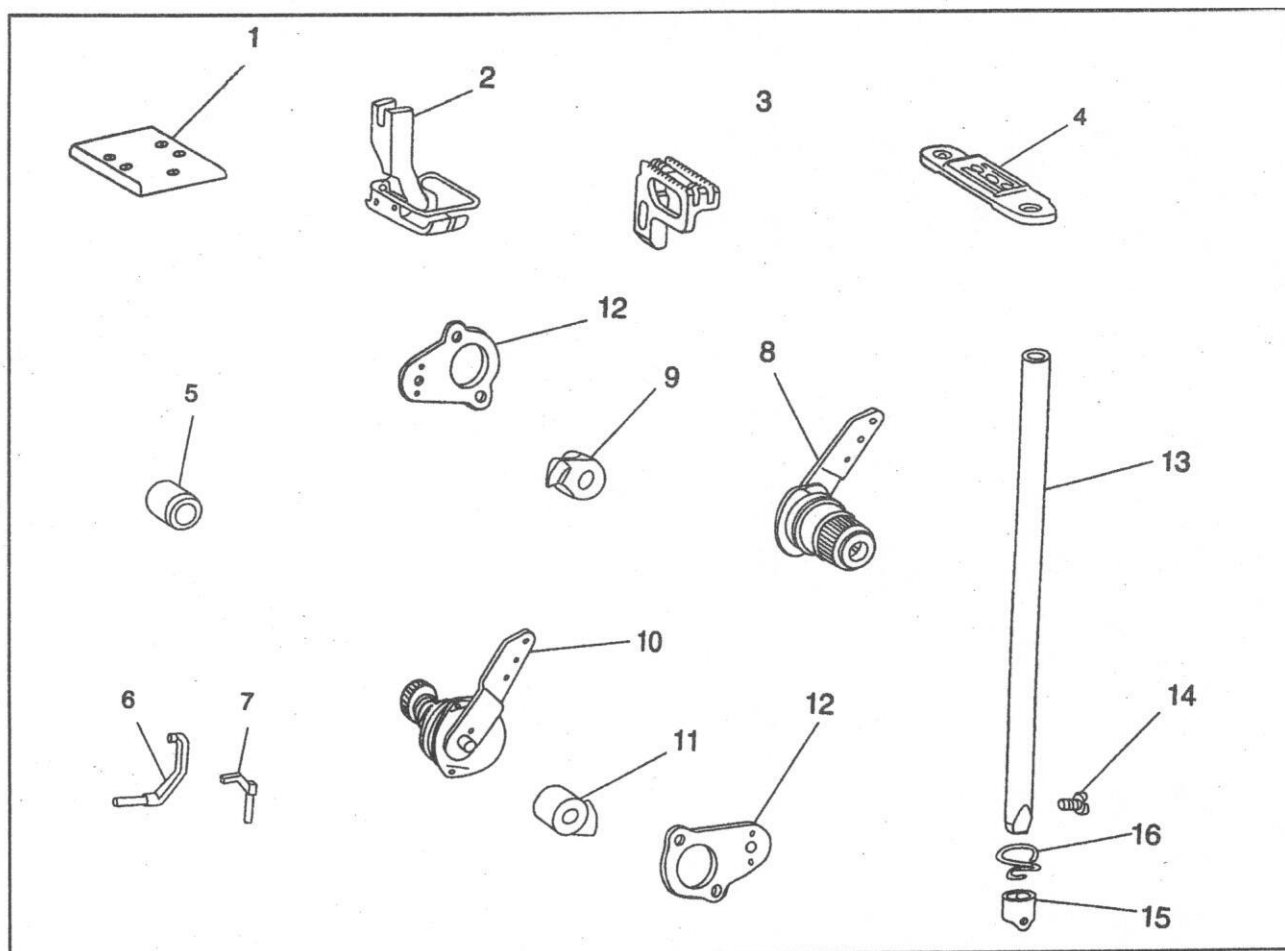
11. 四线团架分组件 Quadruple-thread spool stand asm.



序号 Ref. No.	件号 Part No	名称 Description	数量 Arm. Req.	
1	40-11-1	线架杆下节	Spool rest rod (upper)	1
2	40-11-2	线架杆上节	Spool rest rod (lower)	1
3	40-11-3	线架杆接头	Spool rested joint	1
4	40-11-4	线架杆预防护橡皮	Spool rest rod rubber cap	1
5	40-11-5	线架过线杆	Thread guide asm.	2*
6	40-11-6	线架过线夹	Thread guide asm joint	2*
7	40-11-7	线架过线夹螺钉	Screw	2*
8	40-11-8	导线圈	Thread guide ring	6**
9	40-11-9	线架导线杆夹	Thread guide arm holder	1
10	40-11-10	线架导线杆夹螺钉(A)	Screw	1
11	40-11-11	线架导线杆夹螺钉(B)	Screw	1
12	40-11-12	线架导线杆夹螺母	Nut	2
13	40-11-13	线架导线杆	Thread guide arm	1
14	40-11-14	线架导线杆过线夹	Thread guide arm holder	1
15	40-11-15	线架导线杆过线	Lower thread guide	1
16	40-11-16	线架导线杆过线夹螺钉	Screw	2
17	40-11-17	线架导线杆过线夹螺母	Nut	2
18	40-11-18	线盘架	Spool rest arm.	2*
19	40-11-19	线盘架夹	Thread guide arm joint	2*
20	40-11-20	线盘架夹螺钉	Screw	2*
21	40-11-21	线盘	Spool rest	4***
22	40-11-22	线盘钉螺母	Nut	4***
23	40-11-23	线盘钉	Spool pin	4***
24	40-11-24	线盘钉弹簧垫圈	Spring washer	4***
25	40-11-25	线盘钉垫圈	Washer	4***
26	40-11-26	线团防松垫	Spool cushion	4
27	40-11-27	线架杆紧固螺母垫圈	Washer	2
28	40-11-28	紧固螺母弹簧垫圈	Spring washer	1
29	40-11-29	线架杆紧固螺母	Nut	2
30	40-11-30	线架杆防震橡皮圈	Rubber washer	2

注：单针链缝机配二线团线架，三针链缝机配六线团线架 - 31 -








12. 单针链缝机与双针相对应更换之零件 Model one-needle high speed chainstitcher



序号 Ref. No.	件号 Part No	名称 Description	数量 Arm. Req.
1	40-12-1	附件安装板 Attachment installing plate	1
2	40-12-2	压脚部件 Presser foot asm.	1
3	40-12-3	送料牙 Feed dog	1
4	40-12-4	针板 Throat plate	1
5	40-12-5	弯针曲柄挡圈 Throat collar	1
6	40-12-6	摆动护针杆 Driving needle guard	1
7	40-12-7	固定护针杆 Counter needle guard	1
8	40-12-8	面线夹线器部件 Needle thread tension asm.	1
9	40-12-9	面线松线爪 Tension release latch	1
10	40-12-10	底线夹线器部件 Lower thread tension asm.	1
11	40-12-11	底线松线爪 Looper thread release latch	1
12	40-12-12	夹线器安装板 Tension installing plate	2
13	40-12-13	针杆 Needle bar	1
14	40-12-14	支针螺钉 Screw	1
15	40-12-15	针杆线钩 Needle bar thread guide	1
16	40-12-16	针杆下衬套线钩 Thread guide	1

双针双列与双针单列对应零件变化表 List of parts change

双针双列 Two-needle double-row chain stitch:

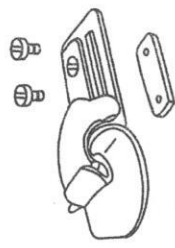

名称 Name	规格 Specifications	针板 Throat plate	针夹 Needles clamp	压脚 Presser foot asm.	送料牙 Feed dog	摆动护针杆 Rear moving needle guard	右固定护针杆 Right fix needle guard	左固定护针杆 Left needle guard
								
*1	1/8"(3.2mm)	40-4-68	40-2-38	40-3-36	40-4-76	40-6-71		
2	5/32"(4.0mm)	40-4-69	40-2-39	40-3-37				
3	3/16"(4.8mm)	40-4-70	40-2-40	40-3-38	40-4-77			
4	7/32"(5.6mm)	40-4-71	40-2-41	40-3-39	40-4-39	40-6-70	40-6-75	40-6-74
5	1/4"(6.4mm)	40-4-42	40-2-35	40-3-10				
6	5/16"(7.9mm)	40-4-72	40-2-42	40-3-40	40-4-78			
7	3/8"(9.5mm)	40-4-73	40-2-43	40-3-41	40-4-79	40-6-72		
8	1/2"(12.7mm)	40-4-74	40-2-44	40-3-42	40-4-80	40-6-73		

双针单列 Two-needle double-line chain stitch:

9	0	40-4-75	40-2-45	40-3-43	40-4-81	40-6-74		40-6-77
---	---	---------	---------	---------	---------	---------	--	---------

双针双列、双针单列附件一览表 List throat of & its accessories

双针双列 Two-needle double-row chain stitch

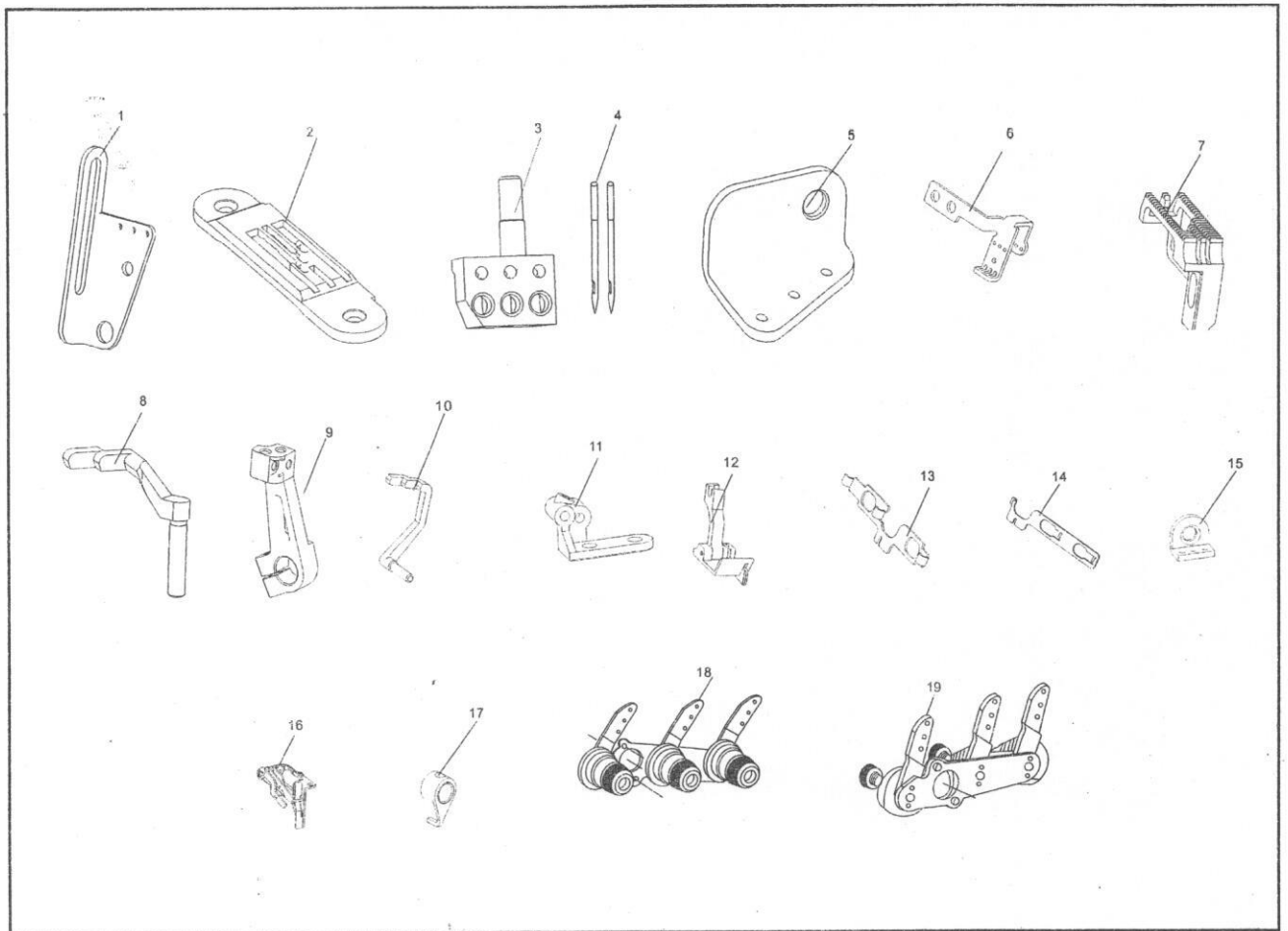
名称 Name	右弯针 Right looper	左弯针 Left looper	推板 Bed slide	凸轮盖 Cam cover	卷边器 Folder
*1	1/8"(3.2mm)				 40-1-47 40-1-48 40-1-49 40-1-50 40-1-44 40-1-51 40-1-52
2	5/32"(4.0mm)			 40-1-18	
3	3/16"(4.8mm)				
4	7/32"(5.6mm)		40-1-25		
5	1/4"(6.4mm)	40-6-47			
6	5/16"(7.9mm)			40-1-49	
7	3/8"(9.5mm)				
8	1/2"(12.7mm)		40-1-47	40-1-50	

双针单列 Two-needle double-line chain stitch

9	0	40-6-78	40-1-48	40-1-51
---	---	---------	---------	---------

15. 三针链缝机与双针相对应更换之零件

Model three-needle high speed chainstitcher



序号 Ref. No.	件号 Part No	名称 Description	数量 Arm. Req.
1	48-1-1	中间导线钩	1
2	48-1-2	针板	1
3	48-2-1	针夹	1
4	48-2-2	机针18#	1
5	48-2-3	针线过线架	1
6	48-2-4-1	挑线杆	1
7	45-3-1-1	送料牙	1
8	48-4-1	摆动护针1/4	1
9	48-4-2	左弯针曲柄	1
10	48-4-3	固定护针杆	1
11	48-4-4	护针杆座	1
12	48-6-1	压脚组件	1
13	48-7-2	底线松线板	1
14	48-7-3	面线松线板	1
15	48-7-4	底线导线钩	1
16	48-7-5	凸轮导线钩部件	1
17	48-7-6	松线曲柄组件	1
18	48-7-7	面线夹线器部件	1
19	48-7-8	底线夹线器部件	1